

Users' Manual
for
APM-N90
Panel Mount Type Printer

December 5, 2001 Rev.C

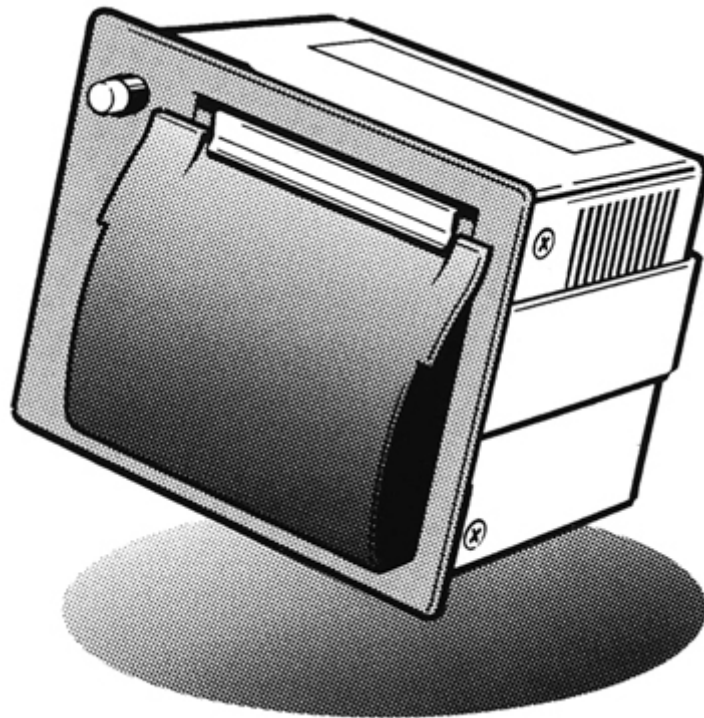

JAPAN SUBCONTRACT INC.

<Contents>

1. Precautions for Use.....	1
2. Unpacking.....	3
2.1 Unpacking.....	3
2.2 Names of Each Part.....	4
3. How to Operate.....	5
3.1 Preparation.....	5
3.2 Paper Setting.....	5
3.3 Test Printing.....	6
3.4 DIP Switch Setting.....	7
3.5 Cable Connection.....	9
4. How to Treat This Product.....	10
4.1 Paper Empty Detection.....	10
4.2 Paper End Signal.....	10
4.3 COP Signal.....	10
4.4 Error Signal.....	10
5. Specifications.....	12
5.1 General Specifications.....	12
5.2 Interface Specifications.....	14
*Precautions for Use.....	18
6. Control Codes.....	20
6.1 List of Control Codes.....	20
6.2 Function of Each Control Code.....	23
7. Trouble Shooting of the Printer.....	50

1.Precautions for Use

When you use this printer, please treat it correctly taking care of the following points.

*Please Check!

Please check the sticker attached this equipment. There are 2 kinds depending on the model.

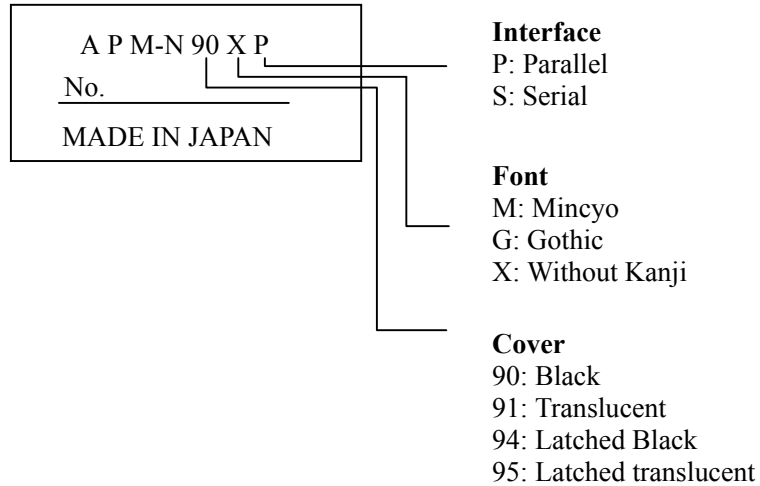

The sticker is different depending on the interface.

On the case of Parallel :

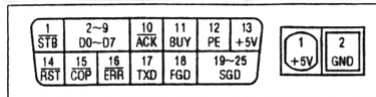

On the case of Serial :

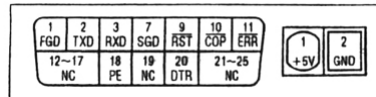

Notice) Do not use 12~17,21~25pin. 25pin is connected to Vcc (+5V).

*Cautions on Installation

Please install this equipment in the places as follows;

Stable place

Places capable to keep temperature range 0°C~50°C

Places within humidity range 25%RH~85%RH (no condensing)

Don't install in the places as follows;

Unstable places and vibrating places

Places exposed to the direct sunlight and dusty places

Places out of temperature or humidity range and places easy to be wet

Near electromagnetic things (motor etc.)and places producing corrosive gas

Places of sudden temperature fluctuation and cause condensing

*Caution to Treat the Product

Please take care of the following points on use of this equipment.

Don't drop it and don't give it any shock.

Don't dissolve or repair it by yourself.

*Caution on Maintenance

When the surface gets dirty, please wipe it with soft and dry cloth. Or after wiping with soft cloth wet with neutral detergent, wipe it with dry cloth.

Don't use chemicals such as thinner etc.

Don't wet inside of the printer by water.

*Power Supply

Don't use any other power supply or cables than the recommended ones.

By using junction connector, putting in/out becomes easy for power supply.

Please use stabilizing power supply of D4.8~5.25V, and 4.3A on full black printing, 2.6A or less on print ratio 25% or less.

Depending on print contents, the current fluctuates largely, so please keep the fluctuation of the power supply voltage within 4.8~5.25V even if the current fluctuates.

*Thermal Paper

Please use the recommended thermal paper.

Recommended Thermal Paper	Mitsubishi Seishi : P220AG
---------------------------	----------------------------

Label AXD114 is not recommended.

Double copy paper is not recommended.

There are other kinds of thermal paper capable to be used.

Please contact to Japan Subcontract.

*Input/Output Connector

D-SUB (25 pin) is used for connector, as it can be used for various purposes.

2. Unpacking

2.1 Unpacking

Please check if there are found all of the following things in the package.

*APM-N90 Printer	1 unit
*Thermal Paper	1 roll
*Users' Manual	1 (this manual)
*Power Supply Connector	Housing : 1 pc Contact : 2 pcs

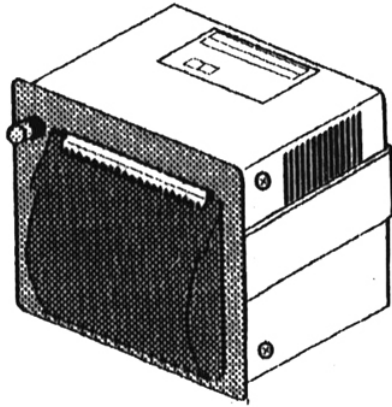

APM-N90 Printer



Thermal Paper



Power Supply Connector

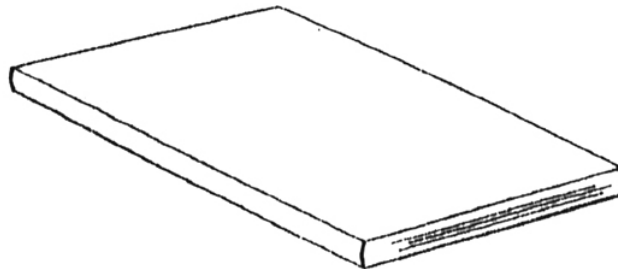

User's Manual

2.2 Names of Each Part

① Paper Feed Switch (FEED)

Feeds the paper during putting this switch.

② Power Supply/Error Lamp

Normally turns on as power supply lamp.

When some error happens, Blinks as error lamp.

Concerning contents of errors, please see “Error Signals”.

③ Connectors for Parallel/Serial Input/Output

Pins to input the data from outside.

④ Power Supply Connector

Loaded Connector : ELR-02V (JST)

Suitable Housing : ELP-02V (JST)

Suitable Contact : LLF-01T-1.3E (JST)

Pressing Tool : YC202 (JST)

Pin Number	Signal	Function
1	Vcc	+5V
2	GND	GND

⑤ DIP Switches for Function Setting

Set each function of the printer. (See 3.4)

<Front>

<Back>

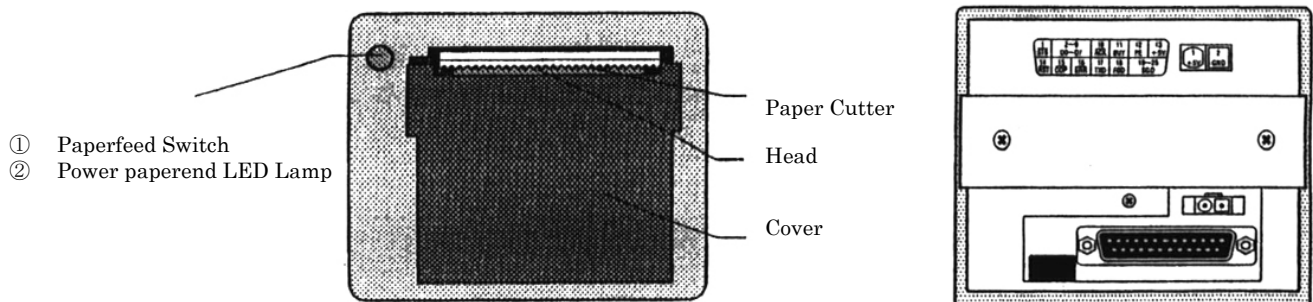

3. How to Operate

3.1 Preparation

When you use the printer for the first time, as the paper is not loaded, please set the Attached paper.

3.2 Paper Setting

On this printer, paper setting is very easy.

Please set as follows.

- ① open the cover taking care about the paper cutter.
- ② Pull out the paper some cm from the paper cutter.
- ③ Put the pulled out paper on the paper cutter lightly, and close the cover.

Then paper setting has finished.

! Outside of the thermal paper is the surface to print.

! Please check if the paper roll can rotate smoothly.

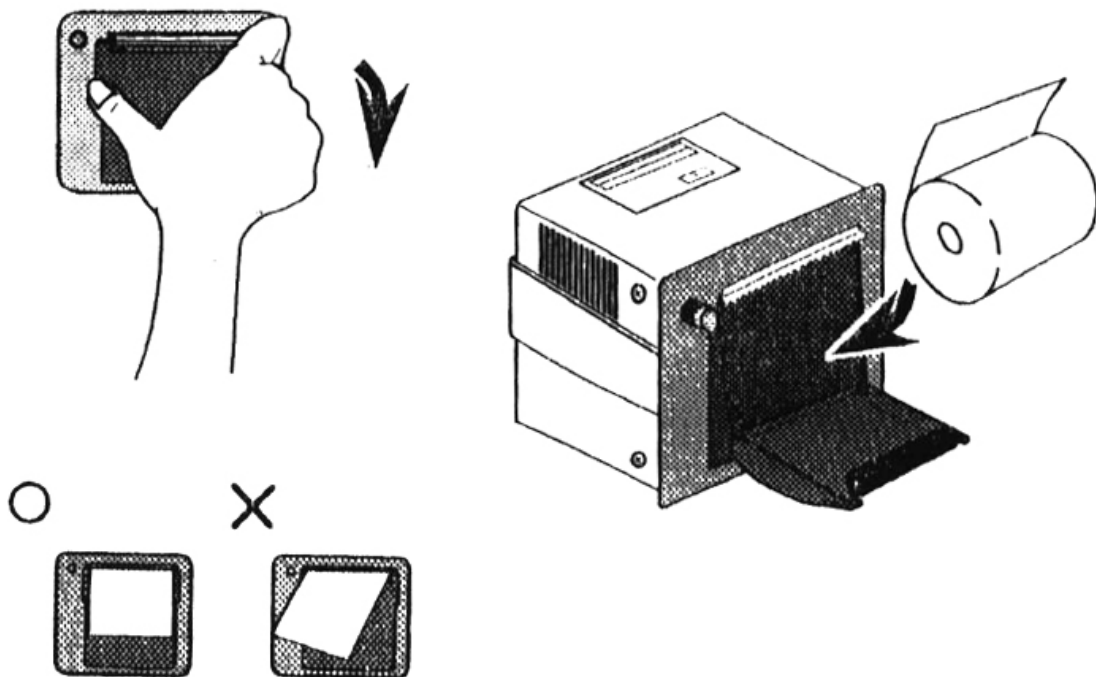

3.4 DIP Switch Setting

Set each function of the printer by DIP switches on the board inside the case.
 Contents set by DIP switches will be valid when turned on or Reset is input from outside.

Please follow the process below.

- ① Turn of the printer.
- ② Depending on the interface that you selected on purchasing, it is set to Parallel or serial.
 When you want to change it, please use sharp-point thing such as driver to Set DIP switch. Don't apply too strong force on DIP switches, or it may damage the switches. See the table below about DIP switch setting.

Here DIP switch setting has finished.

If turned on, the printer operates with the specified contents.*1

Table 3-1 : Functions and Setting Contents of DIP Switches

No.	Functions	ON Side	OFF Side
1	Kanji Code	Shift JIS	Shift JIS
2	Baud Rate Selection	See Table 3-2	
3			
4	Print Density Selection*2	See Table 3-3	
5			
6	Print Mode Selection*3	HEX Printing	Normal Printing
7	Head Mode Selection*4	-	Normal Printing
8	Check Mode*5	Test Mode	Normal Printing

*1 : APM-N90 is set to be initialized on power supply turning on or by inputting outside reset to read setting of DIP Switch. So even if you change the switch during use, the contents of setting will not be changed.

*2 : Print density can be changed by the control code DC2+S+n.

*3: Printing the input data with HEX, keep ON>

*4 : Only for customize switch. Keep OFF usually.

*5 : Check Mode for shipping inspection. Keep OFF usually.

Setting Kanji Code

SW1	ON	OFF
Kanji Code	Shift JIS	JIS Code

Setting Shift JIS

- Without Kanji code (ESK + “K”), ANK + Kanji code can be printed.

Setting JIS Code

- Define the Kanji Code, it defines only Kanji Code.
- Without defining Kanji Code or removing it, it defines only ANK font.

Table 3-2 : Baud Rate Setting

	SW2	SW3
4800	ON	OFF
19200	OFF	ON
9600	OFF	OFF
Auto-setting	ON	ON

Sending the following command, baud rate would be automatically recognized.

\$\$\$\$\$\$\$\$\$\$\$\$* : 24H x 12 + 24H x 1

Table 3-3 : Print Density

Print Density	SW4	SW5
Standard	OFF	OFF
Thick (130%)	ON	OFF
Thicker (223%)	OFF	ON
Thin (70%)	ON	ON

Print Density would be changed by each thermal head.

Adjust it by SW4-5 or command (DC2 + “S” +n)

When exits the factory, setting of DIP Switches is as Table below shows.

No.	Switch	Contents
1	OFF	Kanji Code: JIS
2	OFF	
3	OFF	Baud Rate : 9600 bps
4	OFF	
5	OFF	Print Density : Normal
6	OFF	
7	OFF	Normal Printing
8	OFF	Ignored
		Normal Printing

3.5 Cable Connection

1) Interface Cable Connection

There are 2 types of printers depending on the interface specifications.
Please prepare the suitable cable for each interface specification (model).

*Parallel Interface (APM-N90MP)

*Serial Interface (APM-N90MSR ,APM-N90MST)

- ① Connect taking care about the direction of connector.
- ② Connect the printer to the host device and fix it.
mm screw nut is used for locking on the printer side.
- ③ Connect the power supply cable seeing the following item.
- ④ Turn on the power supply.

When you finish connection, print test printing.

If you print data is sent from the host device to print correctly, connection is completed.

If it doesn't print,. See "7. Trouble Shooting of the printer."

2) Connection of Power Supply Cable

Make a cable by the attached power supply connector and connect the power supply.

- ① Connect the cable to the printer to fit the polarity of each.
- ② Connect the other side of the cable to the stabilized power supply.

Suitable electric wire : AWG#18~#22

(When you use AWG#22, please make it as short as possible.)

If the wire becomes thin, it becomes hard to ignore the resistance value
Of the cable.

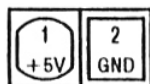

1: +5V

2: GND

! Make the power supply cable and the connection cable to the host device as short as possible and connect it smoothly.

4. How to Treat This Product

4.1 Paper Empty Detection

When the paper ends, LED blinks.

When it blinks, set the paper as soon as possible seeing item 3.2.

When you close the cover, print will start again.

By setting the control code “Reprint position setting”, it is possible to print from the beginning.

4.2 Paper End Signal

When the paper ends, power supply/error lamp blinks, and Paper End signal (active “H”) form input/output connector, the status from TXD by serial communication will be output.

On the host device side, detect paper empty recognizing this signal.

When you finish setting paper, paper end signal will stop output.

4.3 COP Signals

When the cover is opened, power supply/error lamp blinks. Then by COP signal (active “L”) and control code, Status will be output from TXD by serial communication.

4.3 Error Signals

When some error happens, $\overline{\text{ERR}}$ signal (active “L”) will be output.

At the same time power supply/error lamp blinks.

On the host device side, detect errors recognizing this signal.

When an error happens, turn off the power supply switch immediately.

Errors happen on the following cases.

- 1) Temperature of the thermal head is -10°C or less, or 61°C or more.
→Use the printer within the specified temperature range.
- 2) Foreign substance entered into the printer.
→Consult the agent.

- 3) Cover is not correctly closed.
→Close the cover correctly.
- 4) Paper sensor detects paper empty.
→Set the paper.
- 5) Others
→Consult the agent.

After removing the cause of error, turn on the printer.

The following errors are output regardless selection of parallel or serial interface.

Pin No.	Signal	Function	Output Conditions		
CN5-2	TXD	Status Transmission	Serial Communication *1		
CN5-5	$\overline{\text{COP}}$	Cover Open Signal	Cover Open : LOW		
CN5-17	$\overline{\text{ERR}}$ *3	Error Signal	Error Status:LOW	Feed Operation*2	Error Lamp Blinks
			Control PowerSupply Error	○	○
			Head Open Short	○	○
			Head Temperature High/Low Error	○	○
			Thermistor Disconnection Error	○	○
			Paper End	○	○
			Cover Open	○	○
			Label paperError*4	○	○
CN5-19	PE	Paper End Signal	Paper End: High		

*1 : Concerning contents of automatic status transmission, see the control code GS + “a” + n.

*2 : Feed operation is possible during error signal output.

*3 : At the same time that error signal ($\overline{\text{ERR}}$) is output, error lamp blinks.

*4 : Removing the label paper error, put the power supply ON/OFF or input the default signal (RST).

<Error during Serial Data Reception>

Concerning “Parity Error” and “Fleming Error” in serial interface, as it is not possible to return serial transmission, it can be indicated by print out setting DIP-SW-8.

When “Parity Error” happens, prints “!”.

When “Fleming Error” happens, Prints “?”.

5. Specifications

5.1 General Specifications

1) Printer Specifications

Model	APM-90
Printing Method	Thermal Line Dot Method
Character Types	ANK Characters : English and numerical characters Katakana, Spetial characters Downloaded characters, Extra characters
Character Configuration	ANK Characters : 16 × 18 13 × 24
Maximum Number of Printable Characters Per line	ANK 1:24 characters(16x16font,character spacing 0dot) ANK 2:24 characters(13x24font,character spacing 0dot)
Bar-code Types	JAN 8/13 (EAN), CODE39, NW-7, CODE128, ITF
Input Buffer	15K bytes
Applicable Paper Thickness	60~100 μ m
Printing Width	48mm
Maximum Print Speed	30mm/s*1
Total Number of Dots	384 dots/mm
Dot Density	8 dots/mm
Dimensions	90×106×100mm (H×W×V)
Weight of Main Body	Approx. 735g*2
Reliability	Abrasion Endurance : 30km Pulse Endurance : 1×10 ⁸ pulse or more (print ratio : 12.5%)

*1 : Print speed changes depending on the temperature of the head and the voltage.

*2 : Thermal paper is not included.

2) Operation Conditions

- ① Temperature Range : 0°C~50°C
- ② Humidity Range : 25%RH~85%RH

Thermal Paper Specifications (Recommended thermal paper : P220AG)

- ① Paper Width : 60mm
- ② Roll Diameter : 50mm (Max.)
- ③ Roll Length : Approx. 25m

3) Power Supply Specifications

*Full black printing

Power Supply : +5.0~+5.25V, 4.0A or more

*Print ratio 25% or less

power Supply : +5.0~+5.25V, 2.0A or more

5.2 Interface Specifications

1) Parallel Interface

① Specifications

Data Input : 8 bit simple centronics

Hand Shake : $\overline{\text{STB}}$, BUSY , $\overline{\text{ACK}}$

② Hand Shake Timing (Unit : μ sec)

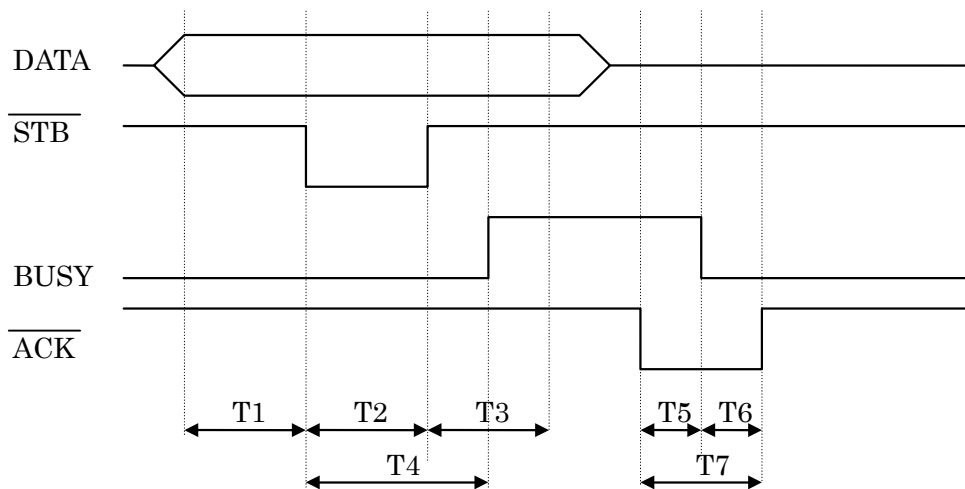

③ Input/Output Signal Level

Item	Symbol	Standard Value			Unit
		MIN	TYP	MAX	
Input "Low" Level Voltage	V_{IL}	0	-	0.8	V
Input "High" Level Voltage	V_{IH}	2.0	-	V_{CC}	V
Output "Low" Level Voltage	V_{OL}	-	-	0.4	V
Output "High" Level Voltage	V_{OH}	2.4	-	-	V

④ Parallel Input/Output Signal Pins

Connector Printer Side : HDBB-25PF (05) (Hirose)

Locking : HD-LNA (05) [Using mm nut] (Hirose)

Pin No.	Signal	Direction	Function
1	STB	Input	Data read in
2	PD00	Input	8-bit parallel data signal "High" on data "1" "Low" on data "0"
3	PD01		
4	PD02		
5	PD03		
6	PD04		
7	PD05		
8	PD06		
9	PD07		
10	\overline{ACK}	Output	Data read in finish
11	BUSY	Output	Data read in impossible
12	PE	Output	Paper end : High*1
13	+Vout	Output	+5V power supply output
14	\overline{RST}	Input	Initialization
15	\overline{COP}	Output	Cover Open: Low*1
16	\overline{ERR}	Output	Error Status: Low*1
17	TXD	Output	Status transmission (Serial communication)*2
18	FGD	-	Frame Ground
19~25	SGD	-	Signal Ground

*1 : See "Error Signals".(P.11)

*2 : Concerning contents of automatic status transmission, see the control code

GS + "a"+n.(P.37)

2) Serial Interface

① Specifications

Data Input : RS-232C

Hand Shake : DTR, RXD, Level TXD, GND

Synchronism Type : Start/stop synchronism type

Baud Rate : 2400, 4800, 960, 19200 bps

Start Bit : 1 bit

Data bit : 8 bits (fixed)

Parity Bit : none

Stop Bit : 1 bit (fixed)

② Signal Timing

When AI-220 receives 1 line of data, it starts printing process.

When 1/2 bit passed from the fall edge of start bit of Receive Data (RXD) “from Mark to Space status”, it reads the status again, and if it is in Space status, it is recognized as Start bit to start serial input. If it gets Stop bit “Mark status”, it starts receiving the next data. When it receives 1 line of data, it starts printing process.

Even during printing process, it can receive data.

When the data inside the input buffer exceeds 15bytes, it makes DTR signal “Mark status” demanding to stop data transmission from the host device temporarily. Then printing process goes on, and when the data quantify becomes 10K bytes or less, it makes DTR signal “Space status” demanding to re-start transmission.

③ Timing Chart

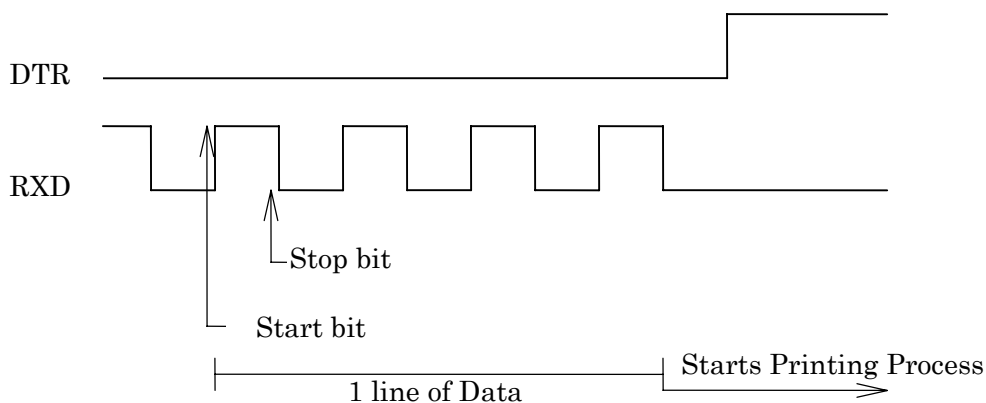

④ TTL Level

Mark=Logic "1" (4.0V~Vcc)

Space=Logic "0" (GND~0.45V)

RS-232C Level

Mark=Logic "1" (-5V~-9V)

Space=Logic "0" (+5V~+9V)

⑤ Serial Input/Output Signal Pins

Connector Printer Side : HDBB-25PF (05) (Hirose)

Locking : HD-LNA (05) [Using mm nut] (Hirose)

Serial Input/Output Pins

Pin No.	Signal	Direction	Function
1	FGD	-	Frame Ground
2	TXD	Output	Status transmission*1
3	RXD	Input	Data input
4~6	NC	-	Not used
7	SGD	-	Signal ground
8	NC	-	Not used
9	$\overline{\text{RST}}$	Input	Initialization
10	$\overline{\text{COP}}$	Output	Cover open : Low*2
11	$\overline{\text{ERR}}$	Output	Error status : High*2
12~17	NC	-	Not used
18	PE	Output	Paper end : High*2
19	NC	-	Not used
20	DTR	Output	Serial busy output
21~25	NC	-	Not used

*1 : Concerning contents of automatic status transmission, see the control code GS + "a" + n.

*2 : See " Error Signals ".

* Precautions for Use

1) Power Supply

- When print rate 100% is needed, please use the stabilizing power supply of DC4.8~5.25V and 4.3A or more.
- Depending on the contents of printing, the current fluctuates largely. So please use the stabilizing power supply in order to keep the fluctuation of power supply voltage within 4.8~5.25V even if the current fluctuates.
- Reset circuit is loaded on APM in order to prevent wrong operation of circuit due to voltage fall down.

2) Installation

- Don't install this board in the places as follows.
- *Places easy to produce static electricity.
- *Near magnetic things such as motors.
- *Strongly vibrating places.
- *Places producing corrosive gas.
- *Places exposed to rain, fog and direct sunlight.

3) Connection

- Make the cables such as connector cable to power supply and connector cable to the host device as short as possible, and connect smoothly.
- Avoid short circuit between pins of connectors.
- Turn OFF power supply before put in/out connectors.

4) Feed Correction

- When the power got on or the resetting time, it feeds about 1mm(16 steps) for correcting the gear of drive part.
- After opening or closing the printer cover, or changing the roll paper, it feeds about 2mm (32steps) for correcting the gear of drive parts. If the paper had feed more, it has a good effect to prevent the cover opened because the power takes forward as the way the cover got closed.

5) Use

- Don't remodel it.
- Turn OFF power supply before put in/out connectors.
- Cable for power supply and I/O are both the production after we received the opened PO so please ask us for the lead time.
- Use the following recommended paper, otherwise print quality and reliability will be affected.

Recommended paper Mitsubishi Seishi:P220AG(High sensitivity paper)

Recommended label AXD114

We do not recommend the double copy paper.

There are other kinds of paper capable to be used. Please ask Japan Subcontract.

- Please read “HTPN Series Thermal Printer Mechanism Technical Guide” on use.
- We have another documents for the commands so please ask Japan Subcontract.

6. Control Codes

6.1. List of Control Codes

	Control Code	Function	Page
Printing Operation	CR	Print and feed one line	23
	LF	Line feed	23
	ESC+"J"+n	Print and feed paper forward n-dot line	23
	DC2+"E"	Set finish printing	23
	FF	Set cutting operation	24
Form Setting	ESC+"0"	Set 4-dot line spacing	24
	ESC+"1"	Set 8-dot line spacing	24
	ESC+"2"	Set 16-dot line spacing	24
	ESC+"3"+n ESC+"A"+n	Set n-dot line spacing	24
	ESC+SP+n	Set character spacing	25
	ESC+"U"+n	Select inverse print	25
	FS+"J"	Select 90deg. turned Kanji characters	25
	FS+"K"	Cancel 90deg. turned Kanji characters	25
	FS+"I"+n	Set 90deg. Right turned character	25
	ESC+"c"+ NUL+n1+n2	Set the length of the page	25
	Character Modification	SO	Set double width with automatic reset
DC4		Cancel double width with automatic reset	26
SI		Set double height with automatic reset	26
ENQ		Cancel double height with automatic reset	26
ESC+"w"+n		Set/cancel double height	27
ESC+"W"+n		Set/cancel double width	27
FS+"W"+n		Set/cancel double width-double height	27
ESC+"I"+n		Set/cancel reverse print	28
ESC+"-"+n		Set/cancel underline	28
FS+SI		Set half width Kanji character	28
FS+DC2		Cancel half width Kanji character	28
Character Set	ESC+"c"+n	Select special characters	29
	ESC+"R"+n	Select the international characters	29
	ESC+"&"+ n1+n2+DATA	Define downloaded characters	29
	ESC+"%" +n	Select downloaded characters	30
	ESC+"K" FS+"&"	Set Kanji mode	30

Character Set	ESC+”H” FS+”.”	Cancel Kanji mode	31
	FS+”!”+n	Set Kanji font size	31
	FS+”C”+n	Select Kanji code system	31
	FS+”2”+n1+ n2+DATA	Define extra characters	32
	FS+”F”+n	Set ANK font	32
	ESC+”Q”+n	Switch IBM code	33
Bit Image	ESC+”v” +n1 +n2+DATA	Set MSB bit image	33
	ESC+”v”+n1 +n2+DATA	Set LSB bit image	33
Ruler line	DC3+”A”	Select ruler line A	35
	DC3+”B”	Select ruler line B	35
	DC3+”V”+ DATA	Write ruler line MSB image	35
	DC3+”v”+ DATA	Write ruler line LSB image	35
	DC3+”D”+n1 +n2	Set ruler line by dot	35
	DC3+”L”+n1 +n2+n3+n4	Set ruler line by line	36
	DC3+”F”+n1 +n2	Set ruler line with repeating pattern	36
	DC3+”+”	Turn ruler line ON	36
	DC3+”-“	Turn ruler line OFF	36
	DC3+”P”	Print one dot line after printing	36
	DC3+”C”	Clear ruler line	37
	DC3+”(“	Continue ruler line control code input	37
Status	GS+”a”+n	Start/stop automatic status transmission	37
Bar Codes	GS+”k”+n+D +NUL	Print bar code	39
	GS+”h”+n	Set bar code height	41
	GS+”x”+n	Set bar code print starting position	41
	GS+”H”+n	Select printing position for HRI Characters	41
	GS+”w”+n1 +n2	Set narrow/wide width	41
	GS+”j”+n	Set the width of JAN module	42
Print Control	DC2+”S”+n	Set print density	42
	DC2+” “+n	Set print control	43

Paper Setting	DC2+"!" +n	Select print paper	44
Supplementary Functions	DC3+"O"	Overwrite ruler line and character in OR mode	45
	DC3+"X"	Overwrite ruler line and character in XOR mode	45
	ESC+"@"	Reset	45
	CAN	Cancel	45
	DEL	Delete one character	45
	AX+"S"	Set re-print position	45
	DC2+"T"	Test printing	46
	ESC+"P" +n	Valid judgement of feed SW	46
	AX+"V"	Print status indication	46
Setting label paper	DC2+"k" +n1 +n2	Set printing start position (label paper mode)	48
	DC2+"L" +n1 +n2	Set the length of label paper	48
	DC2+"m" +S +n1+n2	Detect the mark position	49

6.2. Function of Each Control Code

1) Printing Operation

CR: Print and feed one line

HEX:0D

DEC:13

Prints the data in the line buffer and then feeds the paper with specified line Spacing.

- Each type of printers has its own default value for line spacing.
- Line feed quantity is the total dot line of specified character height and line spacing.
- Any LF code received immediately after CR will be ignored.

LF: Line feed

HEX: 0A

DEC: 10

Provides the same function as CR. But LF code immediately after CR will be ignored.

ESC+"J"+n: Print and feed forward n-dot line

HEX: 1B+4A+n

DEC: 27+74+n

Prints the data in the line buffer and feeds the paper n-dot line forward after feeding specified line spacing.

$0 \leq n \leq 255$ DEC

DC2+"E": Set finish printing

HEX:12 + 45

DEC:18 + 69

Receiving this command, the paper feed to the start of the next printing position
When printing with the label mode.

FF: Set cutting operation

HEX:0C

DEC:12

When there are some data left in the printing buffer, it prints the data and move to The next printing position.

It moves to the top of the next page with putting the feed SW on.

Please use with the command (ESC+"C"+NUL+n1+n2) set the length of the page.

2) Form Setting

ESC+"0": Set 4-dot line spacing

HEX: 1B+30

DEC: 27+48

Set line spacing to 4-dot line.

ESC+"1": Set 8-dot line spacing

HEX: 1B+31

DEC: 27+49

Sets line spacing to 8-dot line.

ESC+"2": Set 16-dot line spacing

HEX: 1B+32

DEC: 27+50

Sets line spacing to 16-dot line. (APM-90 default value)

ESC+"3"+n, ESC+"A"+n: Set n-dot line spacing

HEX: 1B+33+n or 1B+41+n

DEC: 27+51+n or 27+65+n

Sets the character spacing on the right side to n dot.

$0 \leq n \leq 127$ DEC

- The character spacing on the left side is set to 0 dot.
- Default value=4 dots

ESC+SP+n: Sets the character to n-dot line.

HEX:1B + 20 + n

DEC:27 + 32 + n

Sets the character spacing on the right side to n dot.

$0 \leq n \leq 127$ DEC

- The character spacing on the left side is set to 0 dot.
- The default value: HTPN9050=4dots

ESC+”U”+n: Select inverse print

HEX: 1B+55+n

DEC: 27+85+n

Set or cancel the inverse print mode by line.

n=0: Cancel (default value)

n=1: Set

- If the command is set at the beginning of a line, it's effective from that line. But if it's set in a line, it's effective from the next line.
- This command doesn't operate for bit image and ruler line.

FS+”J” : Set 90deg. Turned Kanji characters

HEX: 1C+4A

DEC: 27+74

Turns characters 90deg. to the left.

FS+”K” : Cancel 90deg. right turned Kanji characters

HEX: 1C+49

DEC: 27+73

Turns characters 90deg. to the right.

ESC+”C”+NUL+n1+n2: Set the length of the page

HEX:1Bh + 43H + 0 + n1 + n2

DEC:27 + 67 + 0 + n1 + n2

Select the line number with n1 (lower byte) + n2 (upper byte)

$0 \leq n1n2 \leq 4095$ (Set the length of a page)

The position when this code had input would be the top position of the page.

Please use with FF (Set cutting operation)

3) Character Modification

SO: Set double width character.

HEX: 0E

DEC:14

Sets double width character.

- To be canceled by input of DC4, CR, LF, CAN or ESC + “W” + 0, or by one line full printing.
- Usual characters, double width characters, reversed characters and double height characters can be printed in the same line.
- When the command of double height is set at the same time, the characters will become double width-double height.

DC4: Cancels double width mode set by SO.

HEX: 14

DEC: 20

Cancels double width mode set by SO.

- It's not effective to any other modes than double width mode.
- The default value is this mode.

SI: Set double height with automatic reset

HEX: 0F

DEC: 15

Sets double height character.

- To be canceled by input of ENQ, CR, LF, CAN or ESC + “w” + 0, or by one line full printing.
- Usual characters, double width characters, reversed characters and double height characters can be printed in the same line.
- When the command of double width is set at the same time, the characters will become double width-double height.

ENQ: Cancel double height with automatic reset

HEX: 05

DEC: 05

Cancels double height mode set by SI.

- It's not effective to any other modes than double height mode.

- The default value is this mode.

ESC+”w”+n: Set/cancel double height

HEX: 1B+77+n

DEC: 27+119+n

Sets or cancels double height characters.

n=0: Cancel (default value)

n=1: Set

- After setting of the double height character mode, the following characters will be enlarged to double height.
- Usual characters, double width characters and reversed characters can be printed in the same line and all the characters are printed bottom even.
- When the command of double width is set at the same time, the characters will become double width-double height.

ESC+”W”+n: Set/cancel double width

HEX: 1B+57+n

DEC: 27+87+n

Sets or cancels double width characters.

n=0: Cancel (default value)

n=1: Set

- After setting of the double width characters mode, the following characters will be enlarged to double width.
- Usual characters, double width characters and reversed characters can be printed in the same line.
- When the command of double height is set at the same time, the characters will become double width-double height.

FS+”W”+n: Set/cancel double width-double height character

HEX: 1C+57+n

DEC: 28+87+n

Sets or cancels double width-double height characters.

n=0: Cancel (default value)

n=1: Set

- After setting the double width-double height characters mode, the following Characters will be enlarged to double width and double height.

ESC+”I“+n: Set/cancel reverse print

HEX: 1B+49+n

DEC: 27+73+n

Sets or cancels reversed characters mode.

n=0: Cancel (default value)

n=1: Set

- After setting the reverse print command, the following characters will be printed
white on black background.
- Space between characters is also reversed. But by input of CR or LF, the right space of the character just before is not reversed.
- Space between lines and the underline remains not reversed.

ESC+”-“+n: Set/cancel underline

HEX: 1B+2D+n

DEC: 27+45+n

Sets or cancel (default value)

N=0: Cancel (default value)

N=1~7: Set underline to n dot

- It's possible to repeat setting underline in one line. But regarding thickness of underline, the last specified dot is effective.
- Line space is added with width of the specified underline.
- Underline is effective on the space between characters. But the input of CR and LF makes it ineffective on the right space of the character just before.

FS+SI: Set half width Kanji characters

HEX: 1C+0F

DEC: 28+15

Sets half width Kanji characters.

- After input of this code, the following characters will be printed in half width.
- It's effective only in the Kanji mode.

FS+DC2: Cancel half width Kanji characters

HEX: 1C+12

DEC: 28+18

Cancels half width Kanji characters mode.

- It's not effective on the other modes than the half width Kanji characters mode

4) Character Set

ESC+"c"+n: Select special characters

HEX: 1B+63+n

DEC: 27+99+n

Selects the characters of character code <F8>~<FD> HEX.

n=0: Select usual characters (default value)

n=1: Select special characters

Character Code	F8	F9	FA	FB	FC	FD
Special Characters	÷	Σ				
Usual Characters	〒	市	区	町	村	人

ESC+"R"+n: Select the international characters

HEX: 1B+52+n

DEC: 27+82+n

Outputs the international characters (8 countries).

- Select the characters of character codes <23>~<7E>HEX by setting n. See The table below about n value of each country. n=8: Japan (default value)
- It's possible to set one by each one character.
- See Character Codes Table in Appendix.

$0 \leq n \leq 8$ DEC

0	France	5	Spain
1	U.S.A.	6	Italy
2	Germany	7	Sweden
3	England	8	Japan
4	-		

ESC+"&"+n1+n2+DATA: Define downloaded characters

HEX: 1B+26+n1+n2+font data

DEC: 27+38+n1+n2+font data

It's possible for users to define characters of the character codes <E0>~<FF> HEX.

- Sets the range of downloaded characters defined by n1 and n2.

$\langle E0 \rangle \text{HEX} \leq n1 \leq n2 \leq \langle FF \rangle \text{HEX}$

- Number of font data per character=36 bytes

- Input font data per character following the figure below. Horizontal 8 dots=1 byte

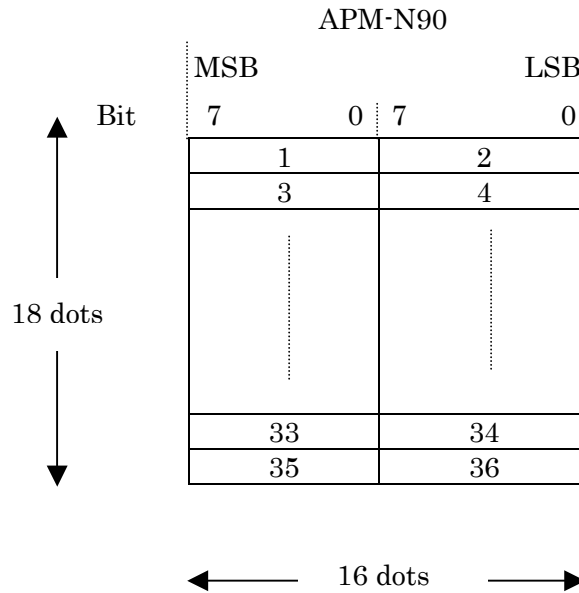

- The data can be cleared by power off and reset.

ESC+”%”+n: Select downloaded characters

HEX: 1B+25+n

DEC: 27+37+n

Selects downloaded characters.

n=0: Cancel (default value)

n=1: Set

ESC+”K”, FS+”&”: Set Kanji mode

HEX: 1C+26 or 1B+4B

DEC: 28+38 or 27+75

Sets Kanji mode.

- As to Kanji, JIS X9052-83 based codes are input by hexa code or decimal code in The order of the 1st byte~the 2nd byte. (in the range <2121>HEX~<7E7E> HEX)

ESC+”H”, FS+”.”: Cancel Kanji mode

HEX: 1C+2E or 1B+48

DEC: 28+46 or 27+72

Cancels Kanji mode.

FE+”!”+n: Set Kanji font size

HEX: 1C+21+n

DEC: 28+33+n

Sets Kanji font size 24 dots/16 dots.

N=0: Sets Kanji font size to 24 dots (default value)

N=1: Sets Kanji font size to 16 dots.

- On HTP-9050/9150, when n=0, 16 characters are printable, when n=1, 24 characters are printable.
- 16 dots and 24 dots size font can't be printed in the same line. Even if you set size change during 1 line printing, it is not effective until printing of that line finishes. It becomes effective from the next line.
- This control code is effective only in Kanji font. It has no effect on ANK characters.

FS+”C”+n: Select Kanji code system

HEX: 1C+43+n

DEC: 28+67+n

Selects Kanji code system.

N=0: JIS Code (default value)

N=1: Shift JIS Code

- Table below shows valid range of Kanji codes.
- Codes out of the range specified in the table are not acceptable.

Kanji Code System	Valid Range	
JIS Code	1 st byte	21h~7Eh
	2 nd byte	21h~7Eh
Shift JIS Code	1 st byte	81h~9Fh E0h~Efh
	2 nd byte	40h~7Eh 80h~FCh

FS+”2”+n1+n2+DATA: Define extra characters

HEX: 1C+32+n1+n2+font data

DEC: 28+50+n1+n2+font data

Defines extra characters.

- n1 and n2 mean character codes to be defined.

N1=<77>HEX

<50>HEX ≤ n2 ≤ <7F>HEX

- The extra characters are made by font pattern of 24×24 dots when 24-dots Kanji Font is set, and 16×16 dots when 16-dot Kanji font is set.
- Input the font data following the figure below. Horizontal 8 dots=1 byte.

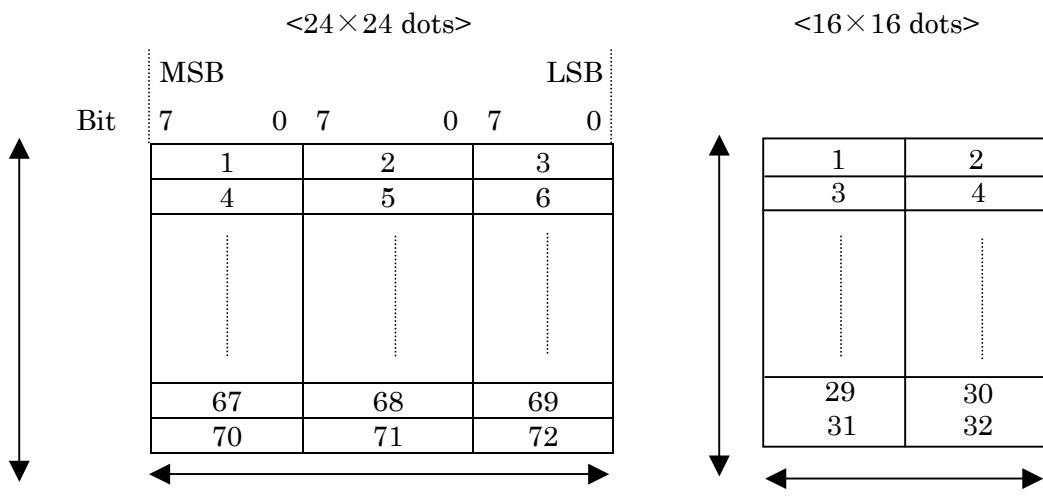

FS+”F”+n:Selects font type

HEX:1C + 46 + n

DEC:28 + 70 + n

Selects font type

	Font type	Character set
0	ANK1	JIS only
1	ANK2	JIS and IBM compatible

ANK1:JIS type font

ANK2:IBM compatible.

Switching JIS,IBM compatible character set refer to ESC+”Q”+n.

Default setting: 0

ESC+”Q”+n: Switch character set of ANK2

HEX:1B + 51 + n

DEC:27 + 81 + n

N=0: JIS character set (default value)

N=1: IBM compatible character set

*) The detail of the each code is refer to the code chart.

5) Bit Image

ESC+”V”+n1+n2+DATA: Set MSB bit image

HEX: 1B+56+n1+n2+image data

DEC: 27+86+n1+n2+image data

Prints the image data by bit image.

- Sets the number of bit image by n1 (lower-order byte) +n2(higher-order byte).
- The number of dot lines= $n2 \times$ The number of data of 1 dot line =The number of image data. Input the data equal to the number of image data.
- Input the image data from the left end of the highest-order dot line to the right end of the lowest-order dot line.
- Data will be printed so that the most significant bit (MSB) appears on the left margin.

ESC+”v”+n1+n2+DATA: Set LSB bit image

HEX: 1B+76+n1+n2+image data

DEC: 27+118+n1+n2+image data

Prints the image data by bit image.

- Sets the number of dot lines of bit image by n1 (lower-order byte)+n2 (higher-order bytes).
- The number of dot lines = $n2 \times 256+n1$
 $0 \leq n1n2 \leq 65535$ DEC
n1=n2=0 is ignored.
- The number of data per dot line=48 bytes
- The number of dot lines set by n1 and n2 \times The number of data of dot line=The number of image data. Input the data equal to the number of image data.
- Input the image data from the left end of the highest-order dot line to the right end of the lowest-order dot line.
- Data will be printed so that the least significant bit (LSB) appears on the left

margin.

<Details >

	384dots		
Line 1	1 st byte	2 nd byte	48 th byte
Line 2	49 th byte	50 th byte	96 th byte
Line 3	97 th byte	98 th byte	144 th byte
Line 4	145 th byte	146 th byte	192 nd byte
Line 5	193 rd byte	194 th byte	240 th byte

As the horizontal 1 line is 384 dots, data of 48 bytes is needed at 1 byte=8 bits.

When you want to print bit image of the above 5 lines, the command data will be as follows.

ESC+"V"+05H+00H+(1st byte)+(2nd byte)+(3rd byte)+.....+(239th byte)+(240th byte)

Example) When the data of 1st byte is FCH, dot pattern will be printed as follows.

● ● ● ● ● ○ ○
 1 1 1 1 1 0 0 =FCH

This is the case of MSB Bit Image. In LSB Bit Image, it will be printed contrast to MSB as follows.

○ ○ ● ● ● ● ● ●
 0 0 1 1 1 1 1 1

6) Ruler Line

- These commands are for continuous printing of vertical lines.
- Supports 2 kinds of ruler line buffers of 1 dot line and possible to select each of them to print.
- When printed characters in the state of ruler line ON, the dot corresponding to the bit which is 1 in the ruler line buffer will be printed black.

DC3+"A": Select ruler line A

HEX: 13+41

DEC: 19+65

Selects ruler line buffer A. (default value)

DC3+"B": Select ruler line B

HEX: 13+42

DEC: 19+66

Selects ruler line buffer B.

DC3+"V"+DATA: Write ruler line MSB image

HEX: 13+56+image data

DEC: 19+86+image data

Writes the image data into the selected ruler line buffer.

- Same as the bit image, input the image data of 1 dot line.
- The number of data per dot line=48 bytes
- Data will be printed so that the most significant bit (MSB) appears on the left margin.

DC3+"v"+DATA: Write ruler line LSB image

HEX: 13+76+image data

DEC: 19+118+image data

Writes the image data into the selected ruler line buffer.

- Same as the bit image, inputs the image data of 1 dot line.
- The number of data per dot line=48 bytes
- Data will be printed so that the least significant bit (LSB) appears on the left margin.

DC3+"D"+n1+n2: Set ruler line by dot

HEX: 13+44+n1+n2

DEC: 19+68+n1+n2

Prints the dots of n1 n2 in the selected ruler line buffer black.

- n1 is lower-order byte and n2 is higher-order bytes.

$0 \leq n1 \leq < FF > \text{HEX}$

$0 \leq n2 \leq < 03 > \text{HEX}$

- Set the position of the dot by $[n2 \leq 256+n1]$ taking the dot on the left end as 0.

DC3+"L"+n1+n2+n3+n4: Set ruler line by line

HEX: 13+4C+n1+n2+n3+n4

DEC: 19+68+n1+n2

Prints the dots from n1 n2 to n3 n4 in the selected ruler buffer block.

- n1 and n3 are lower-order bytes and n2 and n4 are higher-order bytes.
 $0 \leq n1 \text{ or } n3 \leq <FF> \text{ HEX}$
 $0 \leq n2 \text{ or } n4 \leq <03> \text{ HEX}$
- Set the position of the dot by $[n2 \leq 256+n1]$ and $[n4 \leq 256+n3]$ taking the dot on the left end as 0.

DC3+"F"+n1+n2: Set ruler line with repeating pattern

HEX: 13+46+n1+n2

DEC: 19+70+n1+n2

Fills the selected ruler line buffer with the data of 2 bytes set by n1 n2.

- n1 is 8 dots on the left side and n2 is 8 dots on the right side.
 $n1 \text{ and } n2=0 \sim <FF> \text{ HEX}$
- The most significant bit (MSB) of n1 will be printed from the left margin.

DC3+"+": Turn ruler line ON

HEX: 13+2B

DEC: 19+43

Turns ON ruler line.

- After setting of this command, the ruler lines will be printed on the cases of characters printing, line spacing, CR, LF and feeding by ESC+"J".
- Characters will be printed over the ruler lines in the overwrite modes set by DC3+"O" or DC3+"X".

DC3+"-": Turn ruler line OFF

HEX: 13+2D

DEC: 19+45

Turns OFF ruler line.

- After setting of this command, the ruler lines will not be printed.

DC+"P": Print one dot line after printing

HEX: 13+50

DEC: 19+80

When the ruler line mode is ON, if some data is in the line buffer, prints 1 dot line
Of the image of the selected ruler line buffer after printing.

- When the ruler line mode is OFF, feeds the paper 1 dot line.

DC3+”C”: Clear ruler line

HEX: 13+43

DEC: 19+67

Commands the ruler line command (DC3 command) continuously until “)” is
Received.

- Example: the following commands can be shortened as the below. Select ruler
Line A, Ruler line ON, 1 dot printing, Select ruler line B, 1 dot line printing,
Ruler line OFF.

<13>HEX+”(A+PBP-)”

DC3+”(“: Continuous ruler line control code input

HEX:13 + 28

DEC:19 + 40

Commands the ruler line command (DC3 command) continuously until “)” is
Received.

- Example: The following commands can be shortened as the below. Select ruler
line A,Ruler line ON, 1 dot printing, Select ruler line B,1 dot line printing, Ruler
line OFF.

<13>HEX + “(A + PBP-)”

7) Status

GS+”a”+n: Start/stop automatic status transmission

HEX: 1D+61+n

DEC: 29+97+n

Starts or stops automatic transmission of status from serial transmission TXD.

n=0: Stop (default value)

n=1: Start

- When executing by n=1 “Start” or when the status changes after starting, status
data of 2 bytes will be transmitted from TXD.
- After executing this control code, status will be transmitted from TXD
regardless

selection of interface serial or parallel.

- Tables below show the meanings of each bit of transmitted data. “1” indicates the detection is going on.

1st Byte

Bit	Status
0	System Error (Timer observation error)
1	Control Power Supply Error
2	Not Specified
3	Head Short
4	Head Open
5	Thermistor Disconnection
6	Head High Temperature
7	Head low Temperature

2nd Byte

Bit	Status
0	Paper End
1	Cover Open
2	Line (Buffer) Full
3	“0” Fixed
4	“0” Fixed
5	“0” Fixed
6	“0” Fixed
7	“0” Fixed

8) Bar Codes

GS+”k”+n+D+NUL: Bar code printing

HEX: 1D+6B+n+D+<00>

DEC: 29+107+n+D+0

Selects the type of bar codes and prints.

- Selects the type of bar codes by n value.

$$0 \leq n \leq 7 \text{DEC}$$

Values other than n=1, 2, 3, 4, 6 are output by JAN13.

N	Type of Bar Codes
0	Not used
1	Not used
2	JAN13 (EAN)
3	JAN8 (EAN)
4	CODE39
5	Not used
6	NW-7
7	Not used

- Set the bar code data on D.

For CODE39 and NW-7, set the bar code data added with the start bit and the stop bit.

Maximum number of printable characters per line (the start bit and the stop bit are not contained.) is 11.

CODE39:11

NW-7:11

CODE128:11

ITF2OF5:22

- FFH put on the end of the data.

(1) Notice for CODE128 A,B,C

The structure of DATA Character

Start code (select one from CODE A,B,C)

Special character

CODE A,B,C

Each character for CODE A,B,C is used for changing the symbol that follows the CODE.

Once the Code had set, it continues till the last places.

Shift character

This is used for the temporary change (from A to B, B to A)

After one symbol character had changed, shift character automatically returned To the last Code set.

Function character FNC1~4

There are 4 types of Function character and some function for expand the Performance of CODE-128 would given for the each one.

*Notice

- ① Special character is defined by “{“ (7BH) and the one character that continues it.”{“ is defined by sending this character twice.
- ② If “{“ and one character don't adopt to any character, it would be deal with the space code (20h).
- ③ If some character that couldn't use with the selected code set had received, it would be deal with the space code (20h).
- ④ HRI character that apply to the shift character or code set can't be printed.
- ⑤ HRI character of function character is the space character.
- ⑥ HRI character of control character (00H~1FH or 7FH) is the space character.

(2) Notice of the ITF standard

(1) Character Set

Number (0~9)

(2) Symbol structure

Start code

Data character

Stop code

(3) Even number condition of Data

ITF is made from the bar and space so the number of the code have to be the even number.

Example) The code 0367 stands for the number 0367.

(Notice) If the received data was the odd number, put 0 at the top and make it an even number.

GS+”h”+n: Set bar code height

HEX: 1D+68+n

DEC: 29+104+n

Sets the height of bar codes to n dot.

- Default value=80 dots

$$0 \leq n \leq 255 \text{DEC}$$

GS+”x”+n: Set bar code print starting position

HEX: 1D+78+n

DEC: 29+120+n

Sets the print starting position of bar codes by n value.

$$0 \leq n \leq 255 \text{DEC}$$

- If the bar code setting exceeds one line including width of bar codes to be Printed, the exceeded portion will not be printed.

GS+”H”+n: Select printing position for HRI characters

HEX: 1D+48+n

DEC: 29+72+n

Selects printing and position of HRI characters on bar codes printing.

$$0 \leq n \leq 3 \text{DEC (default value: n=2)}$$

N	Printing Position
0	Not print
1	Over bar code
2	Under bar code
3	Over and under bar code

GS+”w”+n1+n2: Set narrow/wide width (It is effective for CODE39,ITF,CODEBAR)

HEX:1D + 77 + n1 + n2

DEC:29 + 119 + n1 + n2

Set the width of the bar code (narrow/wide) by the number of dots.

Both n1 and n2 are affective for the last 2 bits and it is set line below.

N1=0~2:narrow setting

N2=0~3:wide setting(This value depends on the width of n1)

Default value: n1=0 (narrow: 2 dots)

N2=0(wide: 5 dots)

Narrow width dot : Wide width dot

	0	1	2	3
0	2:5	2:6	2:6	2:6
1	3:7	3:8	3:9	3:9
2	4:9	4:10	4:11	4:12

If the width of the bar code got too long, it won't be printed at all.

*) Compatible with the AI-220 board

When printing the NW-7, the ratio of the narrow and wide width for AI-220 is 2 : 6. Please set as n1=0, n2=11. (subsidiary setting: AI-220 2 : 5)

GS + "j" + n: Set the width of JAN module

HEX: 1D + 6A + n

DEC: 29 + 106 + n

Set the width of JAN module with 3 steps.

N=1 0.5times N:W=0.0625 : 0.125

N=2 1timesN:W=0.125 : 0.25

N=3 1.5timesN:W=0.187 : 0.5

Default value is n=2 1 times

9) Printing Control

DC2+"S"+n: Set print density

HEX: 12+53+n

DEC: 18+83+n

Makes the print density n% thicker.

$$10 \leq n \leq 255$$

- Possible to set 10~255% of the standard density.
- Default value is 100%.
- When you set the print density by DIP switch, it is regarded as the default value.

(See the table below.) When you set it by control code, it is required to multiply by 10~255%.

Print Density	Default Value
Standard	0%
Thin	-10%
Thick	+10%
Thicker	+20%

Example: On the case of setting the maximum print density

- Standard head current transmission time=100
- Set +20% by DIP-SW.
- Set 255% by control code.

$$100 \times 1.2 \times 2.55 = 306$$

Thus the maximum print density is 306.

When you set the print density by DIP switch and control code, if the maximum value exceeds 200, print speed may be slower more than 2 times.

DC2 + “ + n: Set print control

HEX: 12 + 20 + n

DEC: 18 + 32 + n

N=0 High speed printing (recommended paper P220AG normal mode)

N=1 Medium speed printing (Do not print while control the motor)

N=2 Low speed printing (Control the current consumption

Default value is n=0 and when it is $n \geq 4$, it would be the high speed printing.

High speed printing

With the P220AG normal mode, printing disposition and motor control would be done together because the printing time is very fast.

As for AI-220, it feeds with printing so some dot gap would happen.

Medium speed printing

After the printing disposition, the motor control would work. There is no gap happened and the high quality printing would be available.

Low speed printing

As same as the medium printing, after the printing disposition, the motor would work. Also, the printing controlling the consumption current is available because it turning on the electricity by partial.

10) Paper Setting

DC2+”!”+n: Select print paper

HEX: 12+21+n

DEC: 18+33+n

Selects print paper.

n=0: P220AG (Mitsubishi Seishi) Usual paper mode

n=1: Copy Paper Mode*

n=2: PD160R (Oji Seishi) High sensitivity paper mode

n=3: forbidden

n=4: Label Paper Mode

- when copy paper printing is set by this control code, normal print operation will repeat 2 times overwriting.
- When printing the label paper, send this command each time before sending the printing data.
- Default value is n=0.

*Thermal Copy paper

Thermal copy paper is made by attaching 2 kinds of thermal papers, putting low sensitivity paper on the surface and high sensitivity paper on the reverse side. It is possible to print 2 pieces at one time using this copy paper.

As the thermal copy paper is composed of two layers of thermal paper. So the print control method is also different from the one of usual thermal paper.

<Cautions for Use>

It is required to treat thermal copy paper in some special way different from usual one because of its characteristics. Please take care about the following points.

1. When the copy paper mode is set, as the driving pulse endurance lifetime.
As the driving pulse is applied 2 times on the head, the printing speed may become slower 2 times or more than the one of usual thermal paper.
2. When you want to accelerate the print speed using copy paper, set usual paper Mode and set the print density higher.

Example) Print paper selection: n =0 (Usual paper mode)

Print density set: n=180-200 (Usual copy paper)

- When set by n=180, print speed will be 70-80% of the standard.
- When set by n=200, print speed will be 60-70% of the standard.

11) Supplementary Functions

DC3+”O”: OR mode overwrite

HEX: 13+4F

DEC: 19+79

Sets the overwriting mode of ruler line and characters to OR.

- Prints black where there are dots of either image or ruler lines and characters.

DC3+”X”: XOR mode overwrite

HEX : 13+58

DEC: 19+88

Set the overwriting mode of ruler line and characters to XOR.

XOR means exclusive OR and prints the overwritten part white.

ESC+”@”: Reset

HEX: 1B+40

DEC: 27+64

Resets the interface. Returns to the first state as if it is newly turned ON.

CAN: Cancel

HEX: 18

DEC: 24

Deletes the data in the line buffer.

DEL: Deletes the last data in the line buffer.

HEX:7F

DEC:127

Deletes the last data in the line buffer.

AX+”S”: Set re-print position

HEX: 0B+53

DEC: 11+83

Sets re-print position when the paper finishes.

- Detecting the following conditions, starts re-printing just after this control code

When recovers.

*Paper end

*Cover open

*Errors such as abnormal head temperature etc.

(But when the recovery is impossible or the contents of buffer is lost, this function will not be executed.)

- If the quantity between the position of this control code and the position where Paper end has been detected exceeds the capacity of printer buffer (16KB), re-Print will not be executed.

DC2 + "T": Test printing

HEX:12 + 54

DEC:18 + 84

Setting this command, it starts test printing.

This command works as same as when pressing the feed button with power ON.

ESC + "P" + n:Valid judgement of feed SW

HEX:1B + 50 + n

DEC:27 + 80 + n

Judge the disposition of the feed SW whether it is valid.

N=0 Feed SW valid (default value)

N=1 Feed SW unvalid

AX+"V": Print status indication

HEX: 0B+56

DEC: 11+86

Prints the status of present setting.

Concerning print format, see the below and the print form of the next page.

<Print Contents of Status Indication>

AX+”V”

Prints the setting contents of DIP-SW and setting mode of the printer as follows.

DIP-SW Parallel

DIP-SW Serial

Parallel

Serial

AI-220 V.1.5H 2000/07/01

AI-220 V.1.5.H 2000/07/01

Data input :Parallel

Data input :Serial

Buffer Capac :16K bytes

Baud rate :9600 bps

Data bit :8 bits

Int. char :Japan

Parity :none

Rom set :No Set

Stop bits :1bits

Paper selec. :Normal

Receive error :Prints'!?’

Print control :High Speed

Buffer Capac :16K bytes

Cut Paper :No set

Int. char :Japan

Rom set :No Set

Paper selec. :Normal

Print control :High Speed

Cut Paper :No set

VersionNo. year month day

Interface formula

.

.

Selection of Int.Char. :

Kanji Rom.yes/no :

Selection of paper :

Selection of print control

Cutter yes/no :

1.2.12 Label Set

Printing start position (only for label)

DC2 + “k” + n1 + n2: Set the position of the printing start

HEX:12 + 6B + n1 + n2

DEC:18 + 107 + n1 + n2

- Define the line number with n1 (lower byte) + n2(upper byte).

It defines the number of line from the label detection to the printing position.

$0 \leq n1n2 \leq 4095$

- When using the label, use this command before using the paper setting command.
- Default value is 0H (0 line) when the power is on.

Set the length of the label (only for label)

DC2 + “L” + n1 + n2: Set the length of label

HEX:12 + 4C + n1 + n2

DEC:18 + 76 + n1 + n2

- Define the line number with n1 (lower byte) + n2(upper byte).

$0 \leq n1n2 \leq 4095$

Set the length from the label detection to the hole by the line.

If it can't detect the hole with feeding more than the set line when detecting the hole, it stop

As the paper error.

- When using the label, use this command before using the paper setting command.
- Default value os 0H (0 line) when the power is on.

DC2 + “m” + s + n1 + n2: Detect the mark position

HEX:12h + 6Dh + s + n1 + n2

DEC:18 + 109 + s + n1 + n2

Feed the paper until it detects the mark.

s: Detection sensor, feeding way, stop condition

Second lower 2 bit is effective.

Bit	Function	0	1
0 bit	Stop condition	mark	no mark
1 bit	Feeding way	forward	backward

Define the line number with n1(lower byte) +n2(upper byte).

$0 \leq n1n2 \leq 4095$

Set the length to the mark detection by the number of the line and it can't detected with the higher set value it would be paper error.

(If it is set as no paper error, is won't be error. If it is set as no mark, the paper would be feed only the default value.)

- HTPN can't use backward feeding.

DIP SW Set

1. Kanji Code default value

ON Shift JIS
OFF JIS Code

2 · 3 Serial communication baut rate

2	3	
OFF	OFF	96000BPS
ON	OFF	4800BPS
OFF	ON	19200BPS
ON	ON	Auto set. Available to set from 2400BPS to 19200BPS.

Send the following command when start communication.

\$\$\$\$\$\$\$\$\$\$\$*(24H*12 2AH*1 Put 2AH at the last)

When sending this command, set 2400BPS ~ 19200BPS.

* Notice) Send the command for check after more than 100ms.

4 · 5 Correction of the printing density

4	5	
OFF	OFF	normal density
ON	OFF	130%

OFF	ON	223%
ON	ON	70%

6 Set HEX damp

OFF	normal printing
ON	HEX damp printing

7

OFF	normal type
ON	customize (only for SS&T)

8 Set check mode (check mode for shipping inspection)

OFF	normal printing
ON	test mode

AX+V" Command Print Form

A	I	-	2	2	0		V	.	1	.	0	0		2	0	0	0	/	0	3	/	0	1
---	---	---	---	---	---	--	---	---	---	---	---	---	--	---	---	---	---	---	---	---	---	---	---

versionNo. date

*	*	*	*	*	*	*	*	*	*	*	*	*	*	*	*	*	*	*	*	*	*	*	*
D	a	t	a		i	n	p	u	t				:	S	e	r	i	a	l				
D	a	t	a		i	n	p	u	t				:	P	a	r	a	l	l	e	l		

Interface Serial Parallel

B	a	u	t		R	a	t	e					:		2	4	0	0		b	p	s	
B	a	u	t		R	a	t	e					:		4	8	0	0		b	p	s	
B	a	u	t		R	a	t	e					:		9	6	0	0		b	p	s	
B	a	u	t		R	a	t	e					:	1	9	2	0	0		b	p	s	

Communication speed 2400bps 4800bps 9600bps 19200bps

D	a	t	a		b	i	t	s					:	8		b	i	t	s				
---	---	---	---	--	---	---	---	---	--	--	--	--	---	---	--	---	---	---	---	--	--	--	--

Data Bit number 8bit

P	a	r	i	t	y								:	n	o	n	e						
---	---	---	---	---	---	--	--	--	--	--	--	--	---	---	---	---	---	--	--	--	--	--	--

Parity none

S	t	o	p		b	i	t	s					:	1		b	i	t					
---	---	---	---	--	---	---	---	---	--	--	--	--	---	---	--	---	---	---	--	--	--	--	--

Stop Bit 1bit

R	e	c	e	i	v	e		e	r	r	o	r	:	I	g	n	o	r	e	d			
R	e	c	e	i	v	e		e	r	r	o	r	:	p	r	i	n	t	s	'	!	?	'

Receive error ignored prints '!' or '?'

B	u	f	f	e	r		C	a	p	a	c	.	:	1	6	k		B	y	t	e	s	
---	---	---	---	---	---	--	---	---	---	---	---	---	---	---	---	---	--	---	---	---	---	---	--

Input Buffer 16K bytes

P	r	i	n	t		d	e	n	s	i	t	y	:	T	h	i	n							
P	r	i	n	t		d	e	n	s	i	t	y	:	N	o	r	m	a	l					
P	r	i	n	t		d	e	n	s	i	t	y	:	T	h	i	c	k						
P	r	i	n	t		d	e	n	s	i	t	y	:	T	h	i	c	k	e	r				

Print density Thin, Normal,Thick,Thicker

i	n	t	.		c	h	a	r	.				:	F	r	a	n	c	e				
i	n	t	.		c	h	a	r	.				:	U	.	S	.	A	.				
i	n	t	.		c	h	a	r	.				:	G	e	r	m	a	n	y			
i	n	t	.		c	h	a	r	.				:	E	n	g	l	a	n	d			
i	n	t	.		c	h	a	r	.				:	S	p	a	i	n					
i	n	t	.		c	h	a	r	.				:	I	t	a	l	y					
i	n	t	.		c	h	a	r	.				:	S	w	e	d	e	n				
i	n	t	.		c	h	a	r	.				:	J	a	p	a	n					

International Character:France,U.S.A.,Germany,Englan,Spain,Italy,Sweden,Japan

C	h	a	r	a	c	t	e	r		S	e	t	:	S	e	t							
C	h	a	r	a	c	t	e	r		S	e	t	:	N	o		S	e	t				

Kanji Rom. Set No set

P	a	p	e	r		s	e	l	e	c	.		:	N	o	r	m	a	l				
P	a	p	e	r		s	e	l	e	c	.		:	R	e	p	r	i	n	t			
P	a	p	e	r		s	e	l	e	c	.		:	L	a	b	e	l					

Paper Selection Normal Reprint Label

P	r	i	n	t		c	o	n	t	r	o	l	:	H	i	g	h		S	p	e	e	d
P	r	i	n	t		c	o	n	t	r	o	l	:	M	i	d			S	p	e	e	d
P	r	i	n	t		c	o	n	t	r	o	l	:	L	o	w			S	p	e	e	d
P	r	i	n	t		c	o	n	t	r	o	l	:	E	q	u	a	l		e	n	e	r

Printing Control High speed, Mid speed, Low speed, Equal speed

7. Trouble Shooting of the Printer

When the printer doesn't operate well or some error happens, please check it following the items below.

①Printer is not turned on.

Check Item	Counter Measure
Is the power supply cable connected?	Connect the power supply cable.
Are the temperature and the humidity within the standard range?	Use it within the standard range of the temperature and the humidity.

②It doesn't feed paper.

Check Item	Counter Measure
Is the paper set correctly?	Set the paper correctly.
Is the roller clean?	Clean the roller.
Is the power supply turned ON?	Turn ON the power supply.
Is the paper fit to the standard?	Use the paper fit to the standard.
Is the cover closed correctly?	Push the cover to close it tightly.

③It doesn't print or it doesn't print normally.

Check Item	Counter Measure
Is the interface cable connected correctly?	Connect the interface cable correctly.
Is the specification of the interface cable suitable?	Make the specification of the interface Cable fit.
Is the paper fit to the standard?	Use the recommended paper.
Is the paper set correctly?	Set the paper correctly.
Is the test print possible?	If it is not possible, consult the agent.
Are DIP switches set correctly?	Set DIP switches correctly.
Is the cover closed correctly?	Push the cover to close it tightly.