

PMS - PROCESSMASTER™ Electromagnetic flowmeters

Sizes: 3mm to 250mm

FEATURES

- Ideal for auto and manual batching applications.
- Integral or remote (2 metres cable) versions.
- Wide flow measurement range.
- Fully bi-directional operation.
- Virtually maintenance free with no moving parts.
- Eliminates headlosses and need for filters.
- Handles wide range of aggressive liquids and slurries.
- Robust construction for industrial use.
- Frequency, analogue and alarm outputs.
- Accuracy: $\pm 0.4\%$ of rate.
- Process temperature: $-25\text{ }^{\circ}\text{C}$ to $130\text{ }^{\circ}\text{C}$.
- New backlit graphical display, with user friendly programming via touchscreen or infrared port.
- Display shows Flowrate and Total (resettable via optional reset button for manual batching).
- Advanced Digital Signal Processing gives unsurpassed performance in harsh environments involving flow fluctuations.
- Empty pipe detection.
- Stainless Steel grounding ring prefitted as standard.



The ProcessMaster™ electromagnetic flowmeters, custom configured for ManuFlo, and wired, programmed, tested and supplied by ManuFlo, are capable of operating over very wide flowranges. They offer quality performance with accuracy of $\pm 0.4\%$ of rate. With no moving parts and an obstruction-less bore, this type of flowmeter guarantees the highest level of performance, unaffected by specific gravity or viscosity variations, or the most contaminated of fluids, whilst maintaining a high degree of accuracy for liquids with conductivity $\geq 5\mu\text{S/cm}$.

A unique self-verifying feature is implemented in ProcessMaster, providing ultra-stable performance over time.

All ProcessMasters are supplied fully wired, programmed to your specific application requirements, and tested, with Total and Flowrate display and outputs all configured. Application examples include use for measuring mining slurries, grouts, oxides, construction chemicals, food industry etc. The uses are wide and far reaching.

size (mm)	Order Code		MINIMUM Flowrate		MAXIMUM Flowrate
	Integral	Remote	(Litres/minute) @ $\pm 2\%$ accuracy *	(Litres/minute) @ $\pm 0.4\%$ accuracy	(Litres/minute) @ $\pm 0.4\%$ accuracy
3	not applicable	PMS003-FR	0.08	0.08	4
6	not applicable	PMS006-FR	0.1	0.4	20
10	not applicable	PMS010-FR	0.3	0.9	45
15	PMS015	PMS015-FR	0.5	2	100
25	PMS025	PMS025-FR	1.5	4	200
40	PMS040	PMS040-FR	3.8	12	600
50	PMS050	PMS050-FR	5.9	20	1 000
80	PMS080	PMS080-FR	15.1	60	3 000
100	PMS100	PMS100-FR	23.6	80	4 000
150	PMS150	PMS150-FR	53.0	200	10 000
200	not applicable	PMS200-FR	94.0	360	18 000
250	not applicable	PMS250-FR	147	600	30 000

* will measure at lower flowrates, but at reduced accuracy.

OPTIONS

-TRB	Totaliser Reset Button	-XCPn	Extra cable (where n = extra cable length in metres)
-DC	17-30 VDC powered	CV12	12 VDC input to 24 VDC output power step-up converter module. 2 Amp.
ANSI-150 PVC or Galvanized Iron connection kits available			

SPECIFICATIONS

	Process Temp	Rating	Electrical Connections
Display/Transmitter		IP65	20mm plastic glands
Sensor	-25 to 130 °C	IP65	20mm plastic glands

Display/Transmitter		Sensor	
Power supply ** (optionally)	90-250 vac @ ≤ 20 VA 17- 30 VDC @ ≤ 12 W # 17- 30 vac	Liquid Conductivity	> 5µS/cm
Pulse Output/Alarm Rating	30V @ 220mA, Open Collector, Galvanically isolated	Sensor cable length (remote only)	2 metres (max: 200 metres)
Pulse o/p frequency	5 kHz maximum	Maximum pressure	as per flanges (1600 kPa)
Pulse Width *	0.1 to 2000.00 ms	Flange type	ANSI-150, ISO 133359
Pulses/Unit	0.1 to 1,000,000.00	Pressure loss	<0.25 bar (at maximum flow)
Outputs	Pulse, High and Low Alarms	Lining material	3-10mm: PFA, 15-250mm: PTFE
Current Output	4 - 20 mA. HART protocol	Electrode material	Hastelloy C-4
Field Bus	PROFIBUS	Grounding Plate	Stainless Steel 316
Housing	Die Cast Carbon Steel, Powder coated, RAL9002.	Terminal Box	Polycarbonate
Total	Litres, m3, kg, etc. Up to 10 digits. Resettable via menu or optional pushbutton.	Housing & Flange	• 3 - 15mm: Stainless Steel. • 25 - 250mm: Die Cast Carbon Steel, Powder coated, RAL9002.
Flowrate	Per sec/min/day/week	Access	Password protected programme.
Accuracy	±0.4% of reading	Vibration Limits	Min: 5 Hz, Max: 150 Hz

5.6 A switch-on current ** Warm-up phase: 30 minutes
* Pulse Width is dependent on Pulses/Unit and is calculated dynamically.

TRANSMITTER CONNECTIONS

Output Pulse

A = "Active" configuration:
4 ... 20 mA, HART
Load: 0 = R = 650 Ω (300 Ω for Ex zone 1 / Div. 1)
Min. load with HART: 250 Ω

B = "Passive" configuration:
4 ... 20 mA, HART
Load: 0 = R = 650 Ω
Min. load with HART: 250 Ω
Supply voltage for the current output, terminals 31/32:
U1: Min. 11 V, max. 30 V

I = internal, E = external

4-20mA

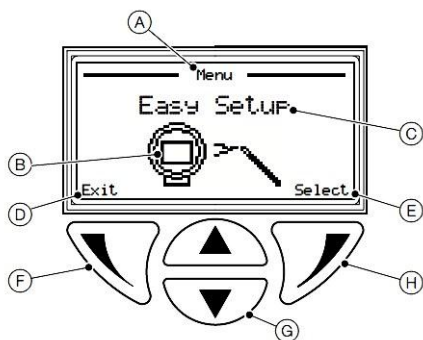

The four keys below the display are used to navigate through the menus and to execute all system commands and selections.



Optional Totaliser Reset Pushbutton (Integral)



Optional Totaliser Reset Pushbutton (Remote)

SENSOR DIMENSIONS

Remote display: Dimensions are mm (inches)

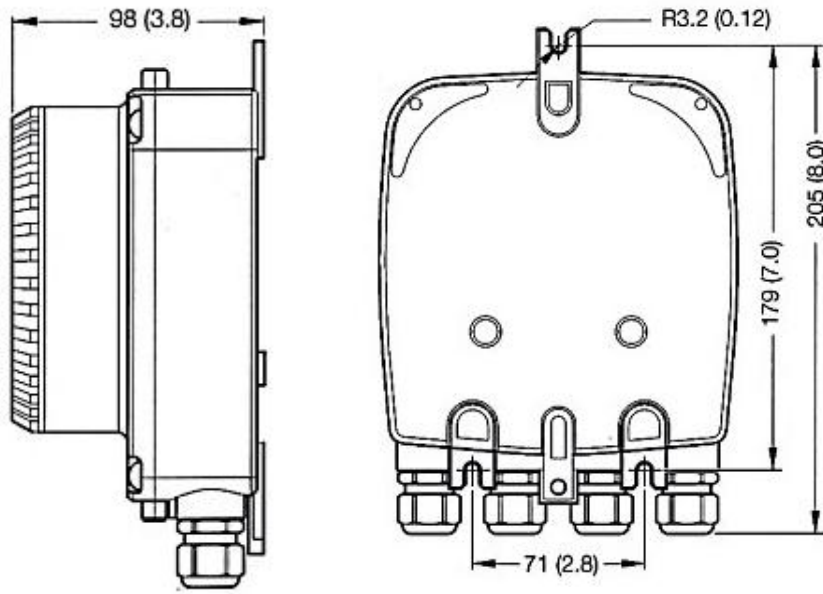

Remote display connections



- Power Cable
- 4-20mA o/p
- Pulse o/p or optional Reset
- Sensor cable

Remote sensor: Dimensions are mm (inches)

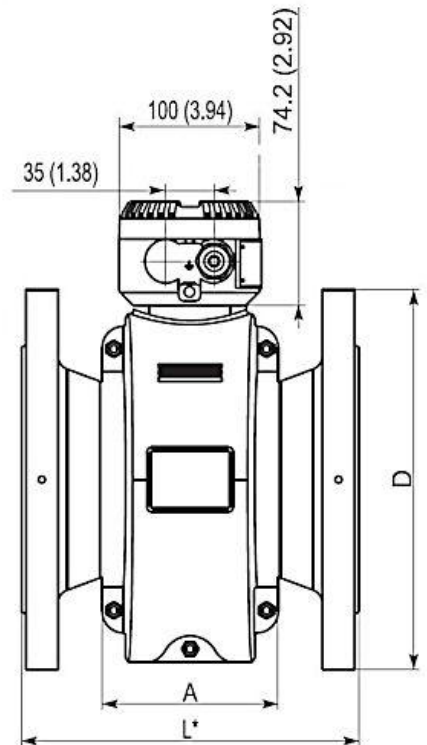
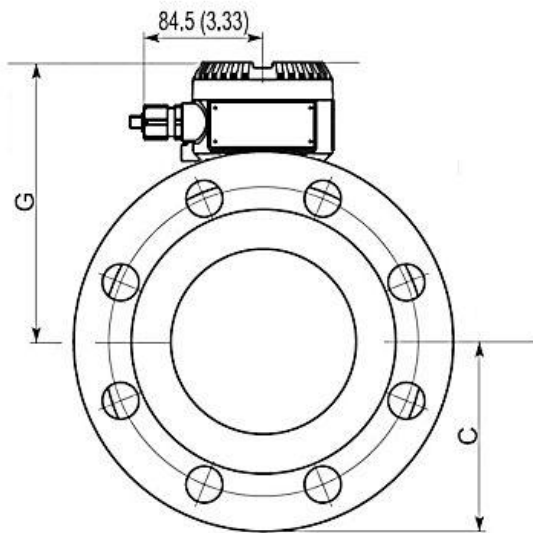

SENSOR DIMENSIONS

Pipe size mm	flange type	Length C mm	Length D mm	Length E mm	Length F mm	Length G mm	Length L (1) mm	Weight (2) (integral) kg	Weight (3) (remote) kg
3	Wafer	82	89	188	255	143	203	not applicable	9.5
6	Wafer	82	89	188	255	143	203	not applicable	9.5
10	Wafer	82	89	188	255	143	203	not applicable	9.5
15	ANSI-150	82	89	188	255	143	203	8	10.5
25	ANSI-150	82	108	188	255	143	203	9	11.5
40	ANSI-150	92	127	195	262	150	203	11	13.5
50	ANSI-150	97	153	201	268	156	203	12	14.5
80	ANSI-150	108	191	212	279	167	203	17	19.5
100	ANSI-150	122	229	234	301	189	203	21	23.5
150	ANSI-150	146	280	291	358	246	305	33	35.5
200	ANSI-150	170	343	331	399	286	355	not applicable	52.5
250	ANSI-150	198	407	346	413	301	455	not applicable	72.5

(1) with grounding plate installed (2) unpacked weight including display (3) unpacked weight, including display and 2 metres cable

Integral: Dimensions are mm (inches)

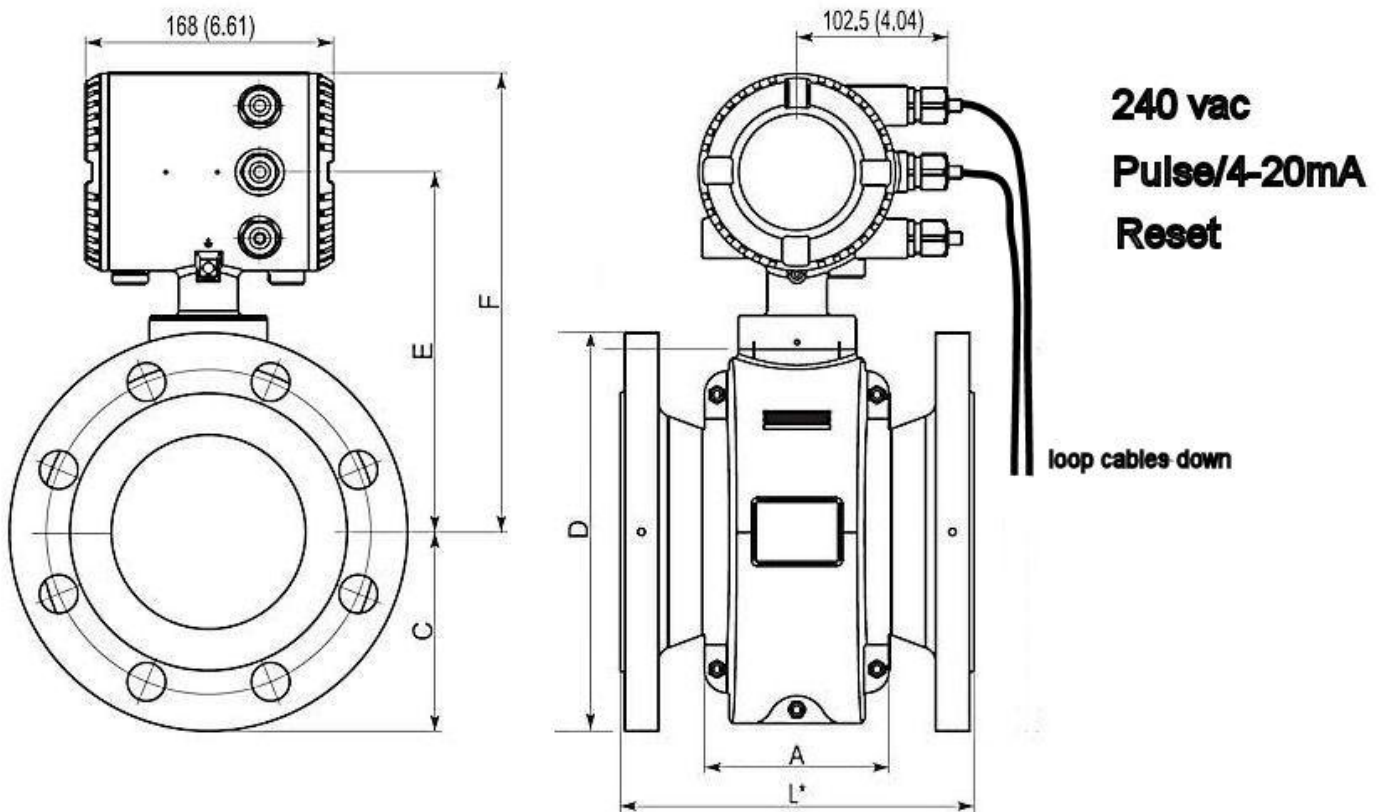

INSTALLATION

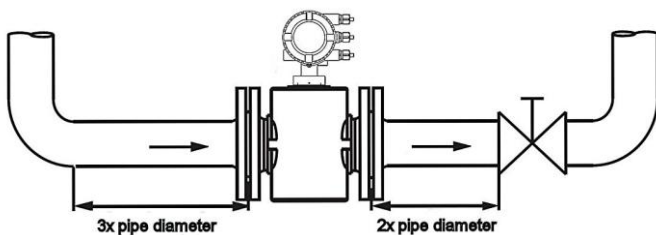

Straight Pipe Requirements

To ensure accurate measurement, must have straight pipe (of length > 3x pipe diameter) upstream of sensor, and also straight pipe (of length > 2x pipe diameter) downstream of sensor.

e.g. 50mm flowmeter requires at least 150mm of straight 50mm Ø pipe upstream, and at least 100mm of straight 50mm Ø pipe downstream.

Note: detailed installation and grounding instructions are in the Manual provided with the flowmeter.

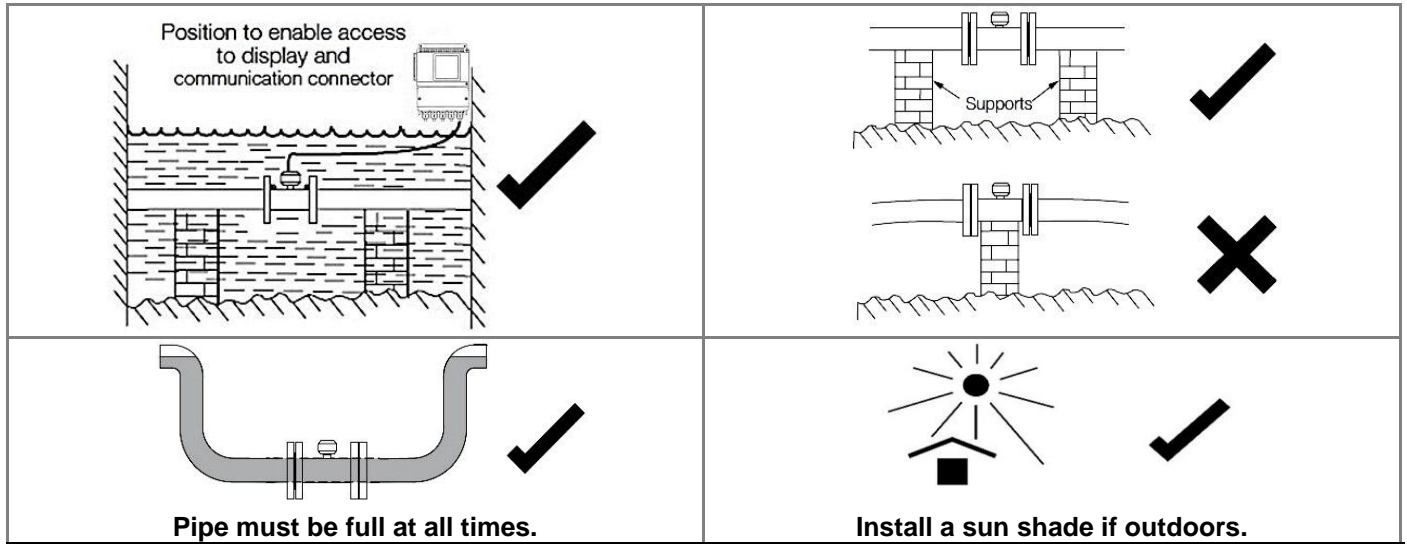

GROUNDING

Note:

- ManuFlo pre-fit a grounding plate on all ProcessMaster flowmeters.
- Detailed installation and grounding instructions are in the Manual provided with the flowmeter.
- Install the flowmeter sensor with grounding plate (3) in the pipeline.
- ManuFlo supply the flowmeter with the terminal lug (2) for grounding plate (3) already connected via a grounding strap to the ground connection (1) on the sensor.
- Use a copper wire (min. 2.5 mm² [14 AWG]) to link the ground connection (1) to a suitable grounding point.
- **For metal pipes (not plastic)** also use a copper wire (min. 2.5 mm² [14 AWG]):
 - to link the grounding plate terminal lug (2) to the flange (4) adjacent to the grounding plate; and
 - to link the ground connection (1) on the sensor to the remaining flange (5).

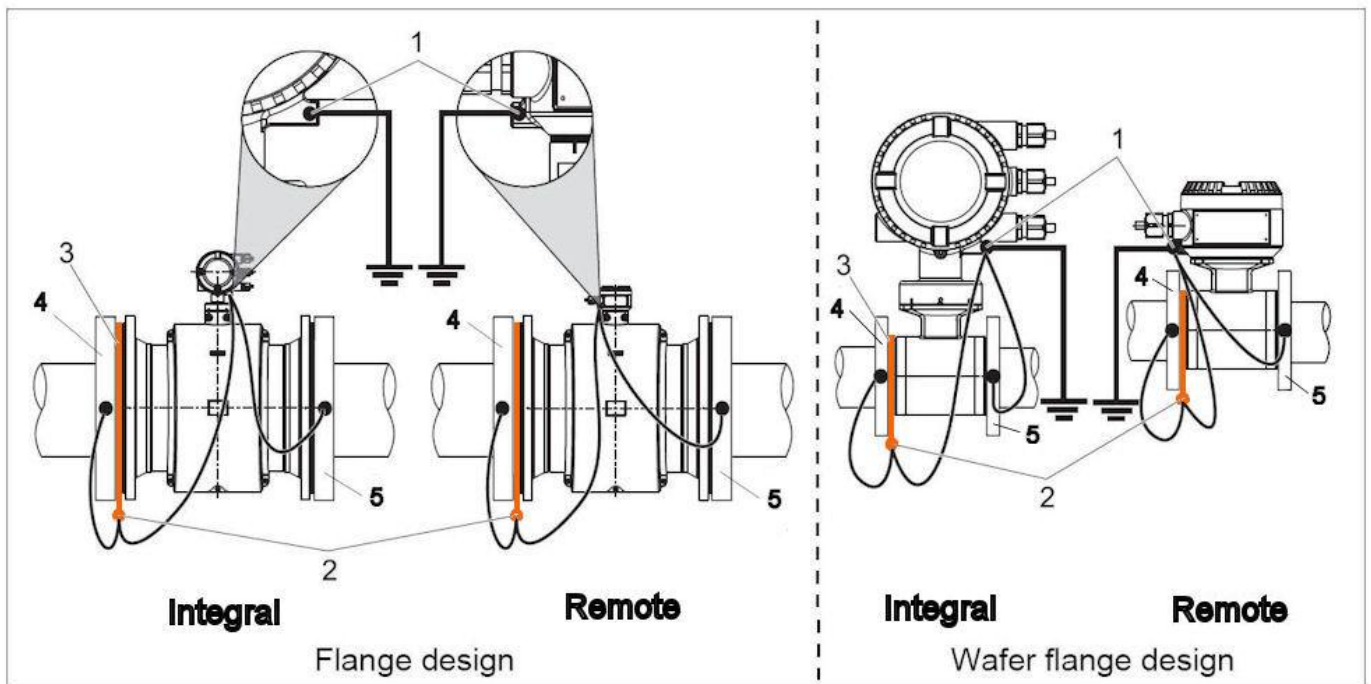

PMS Electromagnetic Flowmeter Installation Guide and Checklist

Note: detailed installation instructions are in the Manual provided with the flowmeter.

LOCATION	
To avoid vibration that may hinder correct flow readings, support the weight of the flowmeter sensor.	<input type="checkbox"/>
The flowmeter's display box must be in an area that allows easy access for reading.	<input type="checkbox"/>
If mounted outdoors:	<input type="checkbox"/>
<ul style="list-style-type: none"> • Install a sunshade, to protect the display box from direct sunlight; and • Install a cover over the display is especially important for integral versions, to help protect against water ingress. 	
To ensure correct flow readings, avoid installing the flowmeter sensor in the vicinity of strong electromagnetic fields , and avoid areas where there is excessive vibration .	<input type="checkbox"/>
Ensure that the chosen location will allow the flowmeter to operate within its environmental rating .	<input type="checkbox"/>
ELECTRICAL	
Have the appropriate power supply (e.g. 90-250 vac or 17-30 VDC) available.	<input type="checkbox"/>
If unsure regarding wiring of outputs, call ManuFlo. Use cable glands provided and <u>make sure the cable glands are properly tightened and sealed</u> to prevent water ingress.	<input type="checkbox"/>
Integral model: If not already performed by ManuFlo, loop the output/power cables downwards and cable tie, to help prevent trailing water entering through the cable glands if the glands are loose.	<input type="checkbox"/>
PLUMBING	
Install the flowmeter sensor in a section of pipe that is full at all times , to ensure correct flow readings.	<input type="checkbox"/>
To prevent turbulence in the flow that may hinder correct flow readings, ensure that there is straight pipe before and after the sensor , of length at least:	<input type="checkbox"/>
<ul style="list-style-type: none"> • 3x pipe diameter before (upstream of) sensor; and • 2x pipe diameter after (downstream of) sensor. e.g. for 50mm diameter pipe, the lengths of straight pipe required are at least 3x50mm=150mm before sensor, and 2x50mm=100mm after sensor.	
Install any gaskets and bonding cables according to the type of pipe.	<input type="checkbox"/>

Strongly contaminated fluids

For strongly contaminated fluids, a bypass connection according to the figure is recommended so that operation of the system can continue to run without interruption during the mechanical cleaning.

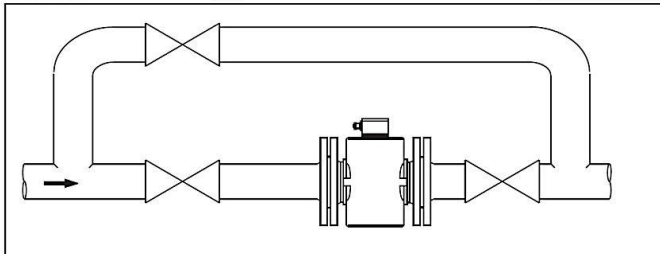

Electrode axis

Electrode axis (1) should be horizontal if at all possible or no more than 45° from horizontal.

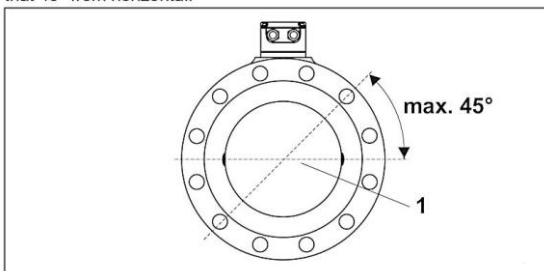

Free inlet or outlet

- Do not install the flowmeter at the highest point or in the draining-off side of the pipeline, flowmeter runs empty, air bubbles can form (1).
- Provide for a siphon fluid intake for free inlets or outlets so that the pipeline is always full (2).

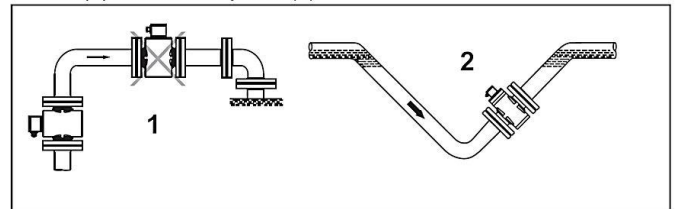

Installation in the vicinity of pumps

- For flowmeter primaries which are to be installed in the vicinity of pumps or other vibration generating equipment, the utilization of mechanical snubbers is advantageous.

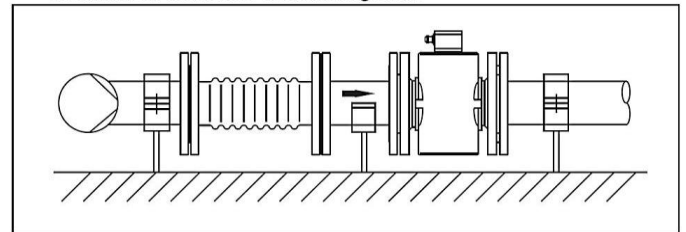

Due to continuous product improvement, specifications are subject to change without notice.