



# RESIDENTIAL END-USE MEASUREMENT GUIDEBOOK

## A GUIDE TO STUDY DESIGN, SAMPLING AND TECHNOLOGY

*Prepared by  
Institute for Sustainable Futures, UTS  
and  
CSIRO*

*For  
Victorian Smart Water Fund, 2008*

# Smart Water Fund

# **RESIDENTIAL END-USE MEASUREMENT GUIDEBOOK**

## **A GUIDE TO STUDY DESIGN, SAMPLING AND TECHNOLOGY**

*Authors*

*D. Giurco, N. Carrard, S. McFallan,  
M. Nalbantoglu, M. Inman, N. Thornton,  
S. White.*

Please cite this report as: Giurco, D., Carrard, N., McFallan, S., Nalbantoglu, M., Inman, M., Thornton, N. and White, S. (2008). *Residential end-use measurement Guidebook: a guide to study design, sampling and technology*. Prepared by the Institute for Sustainable Futures, UTS and CSIRO for the Smart Water Fund, Victoria.

# TABLE OF CONTENTS

- List of tables ..... iii
- List of figures ..... iii
- Abbreviations and glossary of terms ..... iv
- 1 INTRODUCTION ..... 1**
  - 1.1 Residential end-use measurement ..... 1
  - 1.2 This Guidebook..... 1
- 2 FOUNDATIONS OF END-USE MEASUREMENT ..... 2**
  - 2.1 Why do a residential end-use measurement study? ..... 2
  - 2.2 Previous end-use measurement studies ..... 2
  - 2.3 End-use measurement methods ..... 4
  - 2.4 End-use measurement studies in the context of Integrated Resource Planning..... 6
- 3 DESIGNING YOUR END-USE MEASUREMENT STUDY ..... 7**
  - 3.1 Identifying your objectives ..... 7
  - 3.2 Data requirements ..... 9
  - 3.3 Choosing your technology ..... 12
  - 3.4 Choose your sample size ..... 18
    - 3.4.1 Determine unit of analysis ..... 18
    - 3.4.2 Define the population ..... 18
    - 3.4.3 Specify the level of error acceptable and required confidence limits ..... 18
    - 3.4.4 Identify factors that may introduce confounding and variation ..... 19
    - 3.4.5 Choose sampling methodology ..... 19
    - 3.4.6 Calculate sample size..... 20
    - 3.4.7 Prepare sampling frame ..... 23
    - 3.4.8 Implement the sampling plan ..... 23
  - 3.5 Consider constraints..... 23
- 4 TIPS AND TRICKS FOR IMPLEMENTATION..... 26**
- 5 CONCLUDING THOUGHTS – FUTURE OPPORTUNITIES FOR END-USE METERING ..... 28**
- REFERENCES AND FURTHER READING ..... 29**
- APPENDIX 1: PREVIOUS END-USE MEASUREMENT STUDIES ..... 32**
- APPENDIX 2: END-USE MEASUREMENT METHODS ..... 36**
- APPENDIX 3: END-USE MEASUREMENT TECHNOLOGY MANUFACTURERS ..... 48**

## LIST OF TABLES

Table 1: Summary of end-use measurement studies.....	3
Table 2: Overview of data requirements.....	10
Table 3: Summary of available end-use measurement technologies .....	14
Table 4: Composition of dwelling types for residential customers in each Melbourne Region .....	20
Table 5: Sample sizes for clothes washing data (assumed representative of indoor water use) .....	22
Table 6: Sample sizes for outdoor water use .....	23

## LIST OF FIGURES

Figure 1: End-use measurement technology diagram .....	5
Figure 2: End-use measurement study design cycle .....	7
Figure 3: Matching technologies to objectives .....	13
Figure 4: Nutating disc and rotating valve meters (Omega, 2006) .....	37
Figure 5: Smart water meters data transfer (Hauber -Davidson and Idris 2006) .....	43
Figure 6: Example output from Trace Wizard .....	45
Figure 7: Identiflow screen.....	47

## ABBREVIATIONS AND GLOSSARY OF TERMS

AMR	Automated Meter Reading refers to one-way communication system from the water meter & data logger to, for example, a hand-held receiver enabling automated reading via a walk-by or drive-by.
AMM	Automated Meter Management refers to two-way communication between the meter and a central management controller. For example, in addition to communication from meter to hand-held data collector, AMM would allow a signal to be sent back to the meter to change the frequency of sampling.
Bluetooth technology	Bluetooth technology allows raw data of up to 1Mbps to be transmitted across a short range (up to 10m). Bluetooth supports both voice and data and transmits signals between phones, computers and other devices without a landline connection. Bluetooth devices do not need to be in line of sight to send information to each other.
Broadband	A generic term for high-speed digital Internet connections, such as ADSL or cable modems connected to landlines. Broadband can carry multiple channels at once, enabling voice, data and video services simultaneously.
Data Collection Unit (DCU)	This is the main device that collects usage data from meters as part of an AMR system. Also known as the Data Collection Device, Central Station and other similar terms.
Data logger	An electronic memory device which accepts information from the water meter and records it for future use, usually in a form which can be easily read with the help of a personal computer. The data from the logger may need to be downloaded by physically connecting a laptop or by remote transmission (e.g. over mobile phone network).
End-use	An end-use refers to the specific use to which water is put in the home which can be grouped at a number of levels, e.g. indoor or outdoor end-uses. Indoor end-uses could then be further split into water use in showers, toilets, washing machines, taps in bath and basin, kitchen sink, laundry. End-uses are referred to micro-components in the UK.
EUM	End-Use Measurement
Flow trace diagram	This is a graph of the flow rate through the water meter over a period of time. If the resolution of the flow trace is high enough, this can be used to identify water using appliances and their usage patterns (e.g. using Trace Wizard®).
GPRS	General Packet Radio Service is a standard that is an upgrade to a GSM network. It activates a radio wireless modem to send and receive information. This is the second generation of mobile technology. Average throughput rates for GPRS is approximately 20 to 40 Kbps – about the speed that a user would get from a dial-up landline connection.
GSM	Global System for Mobile Technology is a second generation wireless telecommunications standard for digital cellular services. It activates a mobile wireless modem to send and receive information and provides circuit-switched data connections at 9.6 Kbps.
Households	A person or group of people occupying a residential dwelling. A household may be in either a single residential dwelling (freestanding house) or in a multi-residential dwelling (apartment, unit, flats).

LAN	Local Area Network is a small data network covering a limited area, such as within a building or group of buildings.
Meter under-registration	When a water meter does not accurately measure (or infers) the volume of water passing through the meter, and thereby underestimating it. This under-registration occurs from either a low accuracy meter or the normal process of wear that takes place within the unit.
Multi-residential dwellings	A group of more than one household occupying the same building space, e.g. units or flats.
Nutating disc meter	When the measuring chamber is set in motion (by constantly being filled and emptied of water), the magnet rotates and the signal is picked up by an additional magnet or electronic sensor through the wall of the meter.
Point of Use meter	A meter that measures water flow at the actual usage point, such as a tap or toilet.
Pulse probe meters	Meters which have small holes (covered by a rubber cap or such) or a jacket where a probe can be inserted or attached in order to pick up a magnetic pulse every time the mechanical wheel device turns in proportion to the volume of water passing through.
Receiver	This is the device used in Radio Frequency-based AMR systems which receives the meter data transmission for the data collection device.
Single-residential dwelling	A single household occupying a single building space (a freestanding house)
Smart Meters	Smart metering is a term that has a variety of definitions. It is important when using this term to be explicit about the meaning intended. It commonly refers to equipment that reads the volume of water consumed over time, and allows one or two-way communication for the transmission of data (the unique 'smart' feature being that it does not have to be read and collected manually). Another definition has smart metering collectively referring to the water meter and the data logger and a system that sends the collected data to a display unit, either an in-home display or computer. Smart metering as a term does refer to a specific transmission method, it could be by radio, mobile telephony, wireless.
Sub-metering	This report refers to sub-metering as metering individual households in multi-residential dwellings. It can also refer to metering of individual appliances in households, however a clearer term would be 'individual end-use metering'.
Trace Wizard™	This is a software package for analysing flow trace diagrams to identify water end-uses.
Utility	Used alternately to describe a natural resource such as water, gas, and electricity, as well as for the provider of the resource.
Water meter	A device that measures and records water volume used at a property. Types include electromagnetic meters and positive displacement meters &, nutating disc meters.





# 1 INTRODUCTION

## 1.1 Residential end-use measurement

Residential end-use measurement is concerned with understanding where and how water is used in the home. End-use measurement studies seek to elicit information about the technological and behavioural aspects of household water use to determine how much of the total water consumed by a household can be attributed to individual end-uses. Improved understanding of end-uses of water helps to build a picture of how frequently and where water is used in homes, thereby offering significant opportunities for providers to improve water service delivery and long term planning.

## 1.2 This guidebook

The aim of this Guidebook is to help water planners to design and implement effective residential end-use measurement studies. There is currently limited data on end-uses in Australian cities and towns and further research is required. This Guidebook focuses on design considerations rather than analysis of the collected data and is intended to highlight the breadth of issues needing to be considered.<sup>1</sup> It also recommends that specific expertise in experimental design and statistical analysis is needed as part of the end-use measurement study design process.

The Guidebook is organised in four sections following the introduction:

- **Foundations of end-use measurement** summarises relevant previous studies, and provides an overview of currently available technologies for end-use measurement.
- A **guide to designing an end-use measurement study** with five key stages; defining your objective, identifying your data needs, choosing your technology and sample size and considering the budget and resource requirements.
- A compilation of **useful tips for implementation** of end-use measurement programs based on common issues and lessons from previous studies.
- A discussion of the **future of water end-use measurement studies**. This section summarises upcoming technologies and methods for data capture and interpretation and also enhancing water end-use measurement studies by running them in conjunction with energy end-use measurements.

The guide to designing an end-use measurement study presents a planning cycle of key steps, noting critical questions and issues to consider at each stage. The framework is deliberately cyclical – users can begin with any of the steps depending on which is most relevant and pressing in different contexts. It is recommended that readers first review the complete end-use study design cycle to gain familiarity with the framework, then engage with particular steps more closely as required.

---

<sup>1</sup> For information about the application of end-use data and its uses in decision making, refer to Turner et al. (2008) *Guide to Demand Management*.

## 2 FOUNDATIONS OF END-USE MEASUREMENT

### 2.1 Why do a residential end-use measurement study?

Residential end-use measurement studies are an essential input to urban water planning. Understanding where and when people use water in their homes by collecting information about the contribution of various appliances to total water use, the relative split between indoor and outdoor use and/or seasonal and geographical variations in water consumption is essential for determining likely future demands on water supply, detecting system leaks and designing demand management programs. End-use measurement studies can be tailored to meet one or more of a variety of objectives depending on the available budget, technologies and time for the study.

### 2.2 Previous end-use measurement studies

A summary of previous end-use measurement studies is presented here to demonstrate the value of collecting end-use data and to highlight possible constraints which should be considered in the design of future studies.

Table 1 lists some water and energy end-use measurement studies undertaken in Australia, New Zealand, the USA and Canada. More detailed descriptions of these studies are also attached in Appendix 1. Energy end-use measurement studies are included in the list as examples of how monitoring consumption and cost may affect user behaviour. Findings from water, gas and energy end-use measurement studies could be beneficial to all three utility sectors.

These studies have highlighted a number of approaches and practical issues:

1. End-use data is collected to address a range of objectives, such as:
  - Understanding typical end-uses in single family detached homes and patterns across a country (e.g. AWWA Study, USA; REUMS, Melbourne)
  - Measuring impacts of retrofits on water usage (e.g. Tampa, Toronto)
  - Helping businesses to understand and manage their water use efficiently (e.g. Scottish smart water meters)
2. Decisions on equipment selection requires an assessment of practical issues against set objectives.

For example, ultrasonic and magnetic flow meters are easy and quick to install. Nevertheless, installing individual meters in multi-residential dwellings is expensive and time consuming for a large scale study. Data loggers with larger memories are less time consuming and more economical to use. In some instances, loggers may need to be adapted for certain purposes by tailoring devices (e.g. adding microchips to increase memory).

3. Minor implementation issues can have a critical impact on the success of the study. Planning should address simple questions such as:
  - Is there a space available to clamp additional ultrasonic and magnetic flow meters to existing mechanical ones?
  - Is weatherproofing necessary to avoid corrosion of monitoring equipment?

- Are there back-up power sources for powered equipment?
4. Data analysis may become quite laborious where large capacity data loggers are used. Even if analyses are automated, data from data loggers may need to be reformatted for input into software analysis tools. Multiple operators analysing components of the same data set could introduce systematic errors and where possible, algorithms should be developed to automate the process.
  5. Staff training for all steps of data processing is important.
  6. Some studies reported success at identifying separate end-uses (e.g. showers, toilets, washing machines) but not at separating simultaneous end-use events such as showering and tap use.

**Table 1: Summary of end-use measurement studies**

Study	Year	Outcomes
United Kingdom – Bristol County Water Authority	1994	Automatic Meter Reading (AMR) Study Over 3600 Accessplus smart meter units have been installed from 1989 to 1993 as part of a system wide AMR installation.
USA – American Water Works Association	1996-1999	USA and Canada Residential Uses of Water Study Water consumption patterns and demographic factors that affect water use in North American homes were analysed. Indoor water use was relatively stable across all households.
Canada –Toronto Water, Water Saving Devices Study	1997	Twenty-four households were monitored to determine water use and the effectiveness of water-saving devices .Water consumption decreased by 66 Litres/person/day (L/p/d) after the devices were installed.
Australia – Water Corporation Western Australia	1998-2001	Perth Domestic Water Use Study (DWUS) The DWUS collected data on household water usage and identified water usage patterns and trends. The study developed a demand forecasting model and a water use efficiency program.
USA – Tampa Water Department	2004	Residential Water Conservation Study Average household consumption dropped by 46%, from 796 L/p/d to 405 L/p/d after plumbing fixture retrofits in single-family residential dwellings.
Australia – Yarra Valley Water Victoria	2005	Residential End-use Measurement Study The project was able to discern household water end-uses. The shower (22%), washing machine (19%), toilet (13%) and taps (12%) had the highest water use for indoor consumption. Seasonal uses accounted for 25% of consumption.
Australia – Energy New South Wales	2005	Smart Electricity Meter Trial in Queanbeyan and Jerrabomberra Country A trial using smart meter technology in 200 households allowing customers to monitor their energy consumption and costs.
Australia – Gosford/Wyong Water Authority New South Wales	2006	Domestic Potable Water Demand on the Central Coast A pilot study was conducted on a single residential detached household to determine the compatibility of Trace Wizard software with various water meters and data loggers (Foody 2006).

Study	Year	Outcomes
United Kingdom – National Energy Action UK	2006	EDF Energy Smart Metering Trial Trial installing electricity and gas smart meters into 3000 homes over a two year period, aiming to gauge the amount of energy consumers will save by becoming more aware of their energy use.
United Kingdom Scottish Water Authority	2006	Internet Based Reporting System for Water Consumption System shows data recorded by Smart Data Loggers in 15 minute intervals on the internet with daily updates. Scottish Water provides an Automatic Meter Reading (AMR) service for customers with larger networks or needs.
New Zealand Branz Study Report	2007	Water End-use and Efficiency Project Aimed to determine the amount of water used in houses for each type of end-use, time of day and the duration of each end-use event, plus the behavioural and social drivers of end-users, with a focus on hot water and energy savings.
Australia Wide Bay Water	2007	Replacement of the 20,000 meters in Hervey Bay with smart systems (Elster meter, Firefly data logger and Road Runner transceiver) to enable remote reading. The system is designed to improve leak detection and understand customer water use patterns. It is hoped that remote reading will eventually enable 'time of use' billing with water used at night charged at a lower rate to that used during the day.

### 2.3 End-use Measurement Methods

A variety of devices and methods can be used to collect, transfer and analyse end-use data. At one end of the spectrum are methods that rely on manual measurement and reporting including house inspections, log books and questionnaires (less expensive). At the more sophisticated end, enabling larger and more accurate studies, are technological approaches involving smart meters and data loggers (more expensive). Once collected, data must be transferred to a central location for analysis. This transfer can be manual or automated using one-way or two-way communication between the data collector, logger and the final data storage point.

This Guidebook has reviewed currently available methods and technologies for collection, transfer and analysis of water end-use data, focusing on the capabilities and potential uses of metering technologies for end-use measurement. It should be noted that other methods such as surveys and logbooks can play a useful role in end-use data collection, however are not the focus of this guide. An overview is included in Appendix 2 of this Guidebook.

Although it is necessary to consider the full range of methods available when designing an end-use measurement study, the focus of this Guidebook is on those approaches which rely on innovative technologies for collecting end-use data to enable larger and higher resolution studies.

Technologies for end-use measurement can be broadly grouped by their functionality into data capture technologies, data transfer equipment and tools for data analysis.

**Data capture** technologies enable collection of raw data from a household. They include water meters and data loggers.

Technologies for **data transfer** facilitate the collection and delivery of data from the meter/logger to a site where processing and analysis can occur. Data transfer can be manual (e.g. person physically visits house to read meter or download data) or automated.

**Data analysis** technologies assist in the processing and interpretation of raw data into meaningful information about end-uses. Data analysis tools include software packages such as Aquacrafts’s TraceWizard© and WRC’s Identiflow®.

Figure 1 illustrates the range of technologies available for end-use measurement studies and how these are linked to different study objectives.

**Figure 1: End-use Measurement Technology Diagram**

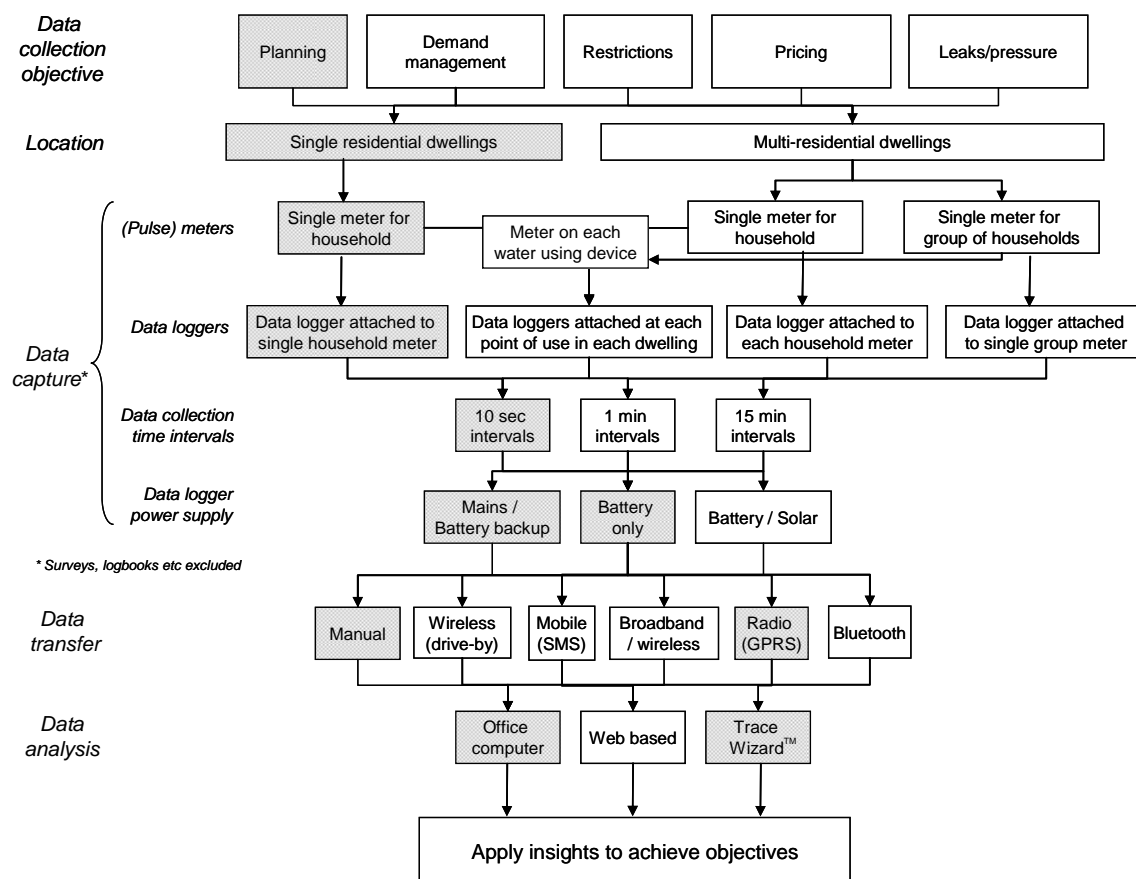

Examining Figure 1 more closely:

The shaded boxes show the most explored end-use measurement path to date. Various data collection objectives of end-use measurement studies are discussed in section 3.1.

Locations represent two options:

1. end-use measurements on single residential dwellings (stand alone houses having one main meter per household) or
2. end-use measurements covering multi-residential dwellings such as a block of units where there may be a single common meter for several households or a meter per household (no comprehensive studies have been identified).

Data capture equipment includes water meters measuring flow rates, data loggers which can record and time stamp pulses from water meters, and other sensors and recorders such as electricity meters that can provide relevant information.

Meters could be installed to record total usage for the whole household at a single point or individual usage of defined appliances.

Data collection time intervals and power supply requirements need to be defined. It may also be necessary to address the need for waterproofing where equipment needs to be installed outdoors (e.g. connected to the billing water meter).

Data on electricity consumption could be simultaneously collected to identify typical end-uses by matching a pattern of electricity usage with appliance usage. For example, there may be a distinct on and off peak profile for a washing machine cycle.

Discrete events could also be identified by adding complementary equipment and modifications. A simple example is putting a switch on the toilet which would register every time it was flushed.

Although excluded from Figure 1, surveys and keeping end-use log-books are also possible approaches where cost/benefit analysis or other case specific constraints do not favour technological approaches. Data transfer and analysis methods referred to in Figure 1 indicate a variety of equipment options as discussed in section 3.3.

### 2.4 End-use measurement studies and Integrated Resource Planning

This sections provides a brief reminder that end-use measurement studies – which may be undertaken to meet a variety of objectives as illustrated in Figure 1 – should be considered linked within the framework of Integrated Resources Planning. The Integrated Resources Planning Framework is aimed at long term urban water planning to ensure that available supply can meet demand, by evaluating both supply augmentation and demand reduction options on an equal basis. Accurate end-use data is of particular relevance to developing accurate end-use-based demand forecasting models, to option design and to the ongoing monitoring and evaluation of implemented options as shown in Figure 2. For further information see the Guide to Demand Management (Turner et al. 2008).

**Figure 2: Key areas of input for end-use measurement data to Integrated Resources Planning**

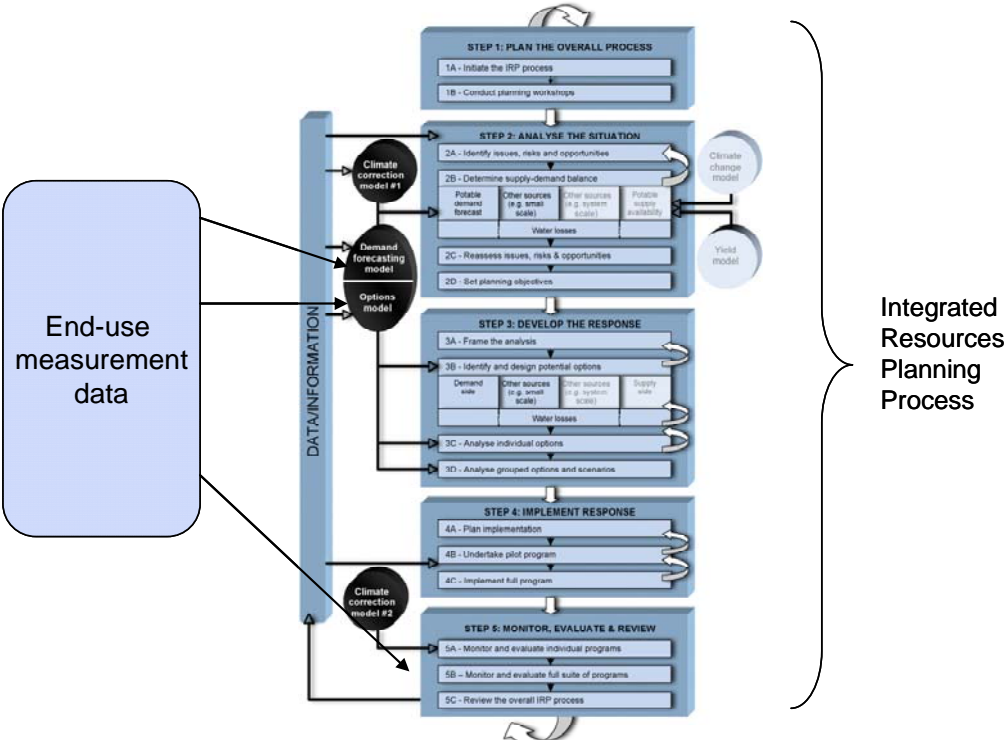

### 3 DESIGNING YOUR END-USE MEASUREMENT STUDY

In the design phase of your end-use measurement study, you will need to consider five aspects:

- Study objective
- Data needs to meet the objective
- Technology to deliver required data
- Sample size
- Resource and other constraints

The design steps outlined in Figure 3 are inter-related and are not always considered sequentially. You may find that constraints may have an impact on your technology selection which may require revising objectives, or data requirements may change if a previous study provides a background level of understanding in your region. Due to the iterative nature of the design cycle, readers are encouraged to gain familiarity with all steps to establish information gaps and critical constraints before thinking through the detail of each stage.

**Figure 3: End-use measurement study design cycle**

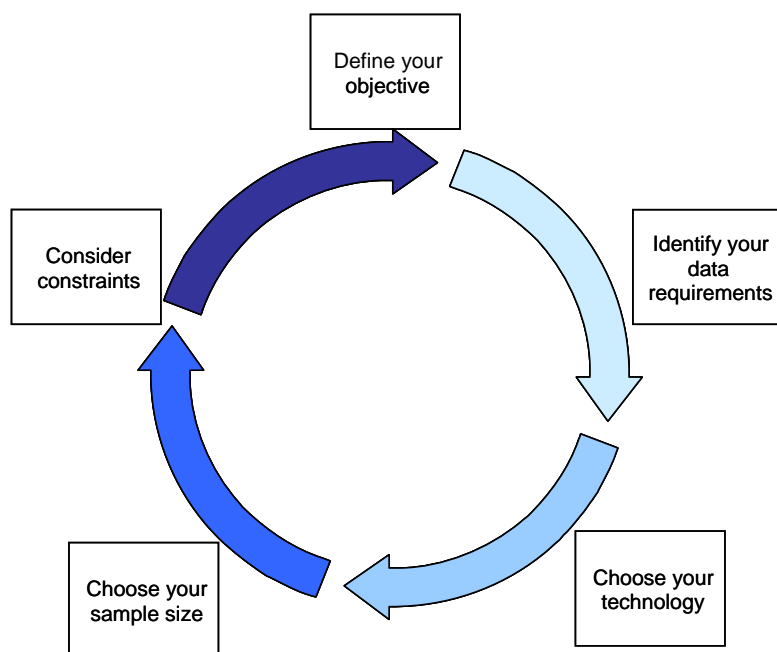

The following sections guide you through each of these steps to help you design your end-use measurement study.

#### 3.1 Identifying your objectives

You need to identify your main objective and goals to help you achieve this objective. For example, are you interested in detecting leaks in the system or do you want to assess the success of a demand management education program?

### Key questions

Why do you want or need end-use data?

What prior work are you building on?

What would you like to learn from the data?

What programs and projects would you like to use the data in?

What other objectives might you have in the future that would require end-use data ?

There are a number of different reasons and motivations across the water industry for collecting residential water use data. You may be collecting end-use data with one or many objectives in mind. Objectives of end-use measurement studies include:

1. *Increasing the accuracy of long term planning* through the use of a demand forecasting tool, for example an end-use model. An end-use model requires end-use data and information on the stock of appliances in use and behaviours (frequency and duration) associated with different end-uses.
2. *Improving the design and assessing the potential effectiveness of restrictions.* End-use measurement studies can inform the design of a water restrictions regime which maximises savings while minimising the loss of services associated with residential water use by understanding where water is used and how it changes during drought and under restrictions.
3. *Designing demand management programs* by improving understanding of conservation potential associated with various water end-uses.
4. *Monitoring and evaluating demand management/water conservation initiatives,* for example, understanding the indoor/outdoor split and observing behaviour changes as a result of education and demand management programs. This knowledge can assist in future program development. At the more sophisticated level, an end-use measurement study with this objective in mind could mean development of a metering program which enables real time end-use monitoring with feedback to customers.
5. *Designing a drought pricing regime* which appropriately reflects available supply and adequate servicing of residential water needs. With highly detailed information, pricing could be based on specific end-uses.
6. Gathering detailed end-use data for potential future *end-use based pricing* (e.g. differential pricing for indoor and outdoor water use, daytime and night-time water use).
7. *Detecting leaks and monitoring the impact of pressure management on the customer side of the meter.* End-use measurement studies can help with accurate detection of leaks and can provide information about the impact of pressure changes on particular end-uses.
8. *Collecting information about a particular end-use* to fill a gap in knowledge, for example improving knowledge about water use associated with particular appliances (front load washing machines vs efficient top loaders, dishwashers vs hand washing, evaporative coolers etc).

You may have many of these objectives or additional goals in mind when designing your end-use measurement study and thinking about how to gain the greatest impact from your



investment in end-use measurement. It is useful at this stage of designing your study to also consider what *future* objectives you may have and how your study might be related. For example, you may be initially interested in leak detection but in future want information to determine a pricing regime. Although the data required for leak detection is likely to be of lower resolution, you may decide to invest in technology which enables higher resolution end-use measurement so that your investment has the capacity to achieve returns in future planning cycles. Objectives can be overlapping and are not mutually exclusive. You may start with one in mind but achieve more.

### **Case study: *Wide Bay Water meters***

Wide Bay Water Corporation, responsible for water and wastewater service provision in Hervey Bay, Queensland, have replaced 20,000 domestic water meters within their jurisdiction with smart metering systems. The smart systems use:

- a standard Elster meter
- a Datamatic data logger called a Firefly
- a Datamatic transceiver called a Road Runner

The initial objectives of the Wide Bay Water project are twofold: improved leak detection and enhanced understanding of customer water use patterns at the household scale. Whilst not initially designed to understand water usage to the end-use level of detail, the project has successfully identified a range of leaks and specific end-uses can be discerned (including outdoor use during restrictions). The project has significantly increased understanding of customer usage (for further information see Britton et al., 2008)

## **3.2 Data requirements**

Once you have determined your objective, you need to consider what data is required to meet that objective.

### Key questions

Are you interested in metering households as a whole or in finding out about water use associated with specific appliances? If you are interested in specific appliances, how many different types of end-uses do you need to measure?

Are you interested in single residential or multi residential dwellings or both?

Do you require data from a particular season or seasons?

Do you require data from particular geographic locations, other regions?

What level of data accuracy do you need in order to meet your objective?

What contribution to your study is needed from raw data (i.e. how much can you get from existing literature and stock surveys)?

Is it possible to use data from other regions or from previous studies (e.g. usage and appliance stock trends)?

Table 2 provides an overview of data required to meet common end-use measurement study objectives. You will need to consider the data requirements outlined according to study objectives in Table 2 in parallel with additional parameters including dwelling type, seasonal variation etc (as outlined in the 'key questions' box above). Additionally, in many cases a combination of current and future objectives will need to be considered. There are often synergies between objectives in terms of required data. An understanding of overlapping data requirements for multiple objectives will reduce the total cost of end-use measurement studies in the longer term, if not immediately.

**Table 2: Overview of Data requirements**

Objectives	Data requirements
<p><i>Increasing the accuracy of long term supply-demand planning</i></p>	<p>The accuracy of long-term supply-demand planning can be increased with more comprehensive information and depends on the level of resolution with which you aim to undertake supply-demand planning with respect to water use (e.g. end-used based, sector-based, litres per capita) and with respect to location (city-based average data, suburb specific, household specific). For sector and end-use based forecasts you will need to obtain data for different dwelling types to ensure differences in water use are incorporated into scaled-up conclusions about local, regional or state water use. For broader end-use measurement studies it might be possible to assume data from one areas may be relevant for another, but it is important to note that specific end-uses (e.g. air conditioners) are region specific.</p> <p>As a goal of this kind of study is to gain a comprehensive picture about demand for water, it is important to structure your study so as to see if there are significant variations in water use over time and/or between seasons.</p> <p>You may repeat the study infrequently (e.g. every 5 yrs), however the duration of each study must be adequate to gain a picture of water use over time (e.g. one month in summer and winter)</p>
<p><i>Improving the design and assessing the potential effectiveness of restrictions.</i></p>	<p>To predict or assess the impacts of restricting water consumption by particular end-uses and times you will need quite detailed information about the targeted end-uses or categories of end-use (e.g. outdoor end-uses). You may need technical information about appliance stocks. You will also need some understanding of the behavioural aspects of water use, i.e. how and when certain water consumption events occur. For accurate targeting of restrictions, metering will need to occur at the sub-household level to, at minimum, determine the split between indoor and outdoor water use - current technology can only make this distinction partially. Some of this information may be able to be gleaned from data collected during previous restriction periods.</p>
<p><i>Designing demand management programs</i></p>	<p>To target a demand management program most effectively you will need specific information about the relative water use of different appliances, variations in use between locations. You will also need information about current appliance stocks (i.e. how many top loading vs. front loading machines are in service) and typical behaviours associated with different end-uses.</p>

Objectives	Data requirements
<i>Monitoring and evaluating demand management/water conservation initiatives</i>	Detailed monitoring and evaluation of demand management or other conservation initiatives will require similar information to that outlined above. However, it is also possible to gain a broad brush picture of water saved by collecting lower resolution data i.e. whole of household information using customer meter data and an adequate sample size. Household water use data would need to be collected regularly and/or extensively to provide the best indication of the savings associated with particular conservation initiatives.
<i>Designing a drought pricing regime</i>	If your aim is to design a drought pricing regime, meters need to be read frequently during drought. Although this could be done manually, telemetric meter readings from all households would facilitate the administration of any future drought pricing initiative that may be introduced. To meet this objective, a similarly coarse pulses per litre signal to that used in meeting the leak detection objective could be used as only total usage over a set period is required. In contrast to the leak detection objective, to meet the drought pricing objective equipment would be required to be installed across all properties.
<i>Designing an end-use based pricing regime</i>	In future a water pricing regime based on the split between indoor and outdoor water use or based on the relative water consumption of different appliances would require data which matches the amount of water used with household appliances e.g. toilets, taps, washing machines, hoses. Such a technology to automate deliver of this data is yet to be commercialised.
<i>Detecting leaks and monitoring the impact of pressure management on the customer side of the meter</i>	In seeking to identify leaks more readily on customer properties, the 'real-time' element of water consumption measurement is more important than discerning individual end-uses. The measurement frequency required to detect leaks could be relatively infrequent (e.g. 0.5 hrs) with unaccounted night flows prompting further investigations of leaks. The time step can be coarse as only total usage is required (rather than discerning end-uses). Meters could have a resolution of one pulse per 0.5 L for detecting leaks if this is the only objective. If seeking to meet additional objectives then higher resolution meters are required.
<i>Collecting information about a particular end-use</i>	End-use information is available from a stock survey, by metering the end-use in question, or by installing a metering system capable of distinguishing between different end-uses. You will probably find it most useful to undertake a combination of these things. A stock survey will provide you with a base level information about the occurrence of older appliances compared with newer efficient appliances. Metering at the end-use level, while more resource intensive, can provide a picture of how and when the appliance in question is used. Installing a metering system capable of distinguishing between different end-uses will enable you to characterise how and when a number of appliances are used. This will be particularly useful if your objective is to compare end-uses e.g. comparing hand washing of dishes with dishwashers.

Objectives	Data requirements
<i>A combination of objectives</i>	Consider what future objectives you may have and how your study might be related to those objectives. For example, you may be initially interested in leak detection but in a year's time want information to determine a pricing regime. Although the data required for leak detection is likely to be of lower resolution, you may decide to invest in technology which enables higher resolution end-use measurement so that your investment has the capacity to achieve returns in future planning cycles.

Overall, the data requirements will inform which approaches are used to gather the end-use measurement data, namely type of meter or indeed surveys, logbooks or drawing information from the literature (i.e. other end-use measurement studies). Deciding which data can be utilised from other studies and which need local data to be collected is context specific. For further information see Turner et al. (2008).

### 3.3 Choosing your technology

A range of end-use data collection, transfer and analysis technologies are available. Your choice of technology will depend on your objective, data needs and financial resources.

#### Key questions

What resolution of data do you need? Do you want to measure one or more end-uses? What technologies are available which can provide the required resolution?

What is your technology budget?

Do you require complete automation or do you have staff who can manually collect and/or analyse data?

How will you power your equipment? Does the equipment require mains power or will battery power be sufficient for the duration of your study?

Are you planning to install the technology only for the duration of the study or will you leave it in place permanently?

Does the equipment require security or weatherproofing measures?

There are a number of technologies available for end-use measurement and analysis. You will need to select a combination of available technologies for data capture (metering and data logging), data transfer and data analysis.

Selecting the best available methodology or tool for data capture is a trade-off between cost and reliability of data. Study plans are often tailored to meet case specific constraints by making compromises in sample size, data frequency and durations. Due to the case-specific nature of constraints and objectives, this Guidebook can not offer a simple decision tree to answer the question "which equipment should I use?". What is offered here is an overview of some common approaches which could help you in designing a new end-use measurement study.

The required functionality of equipment for meeting objectives increases the more comprehensive objectives become, as shown in Figure 4. Technology in place to meet more ambitious objectives is also able to meet lower level objectives. Please note that the diagram is

intended to be indicative rather than comprehensive – some planning related objectives may in fact be more complex in terms of data and technology required than demand management objectives. The specific objective you have in mind for your study will provide the best indication of what data resolution/technologies you require.

**Figure 4: Matching technologies to objectives**

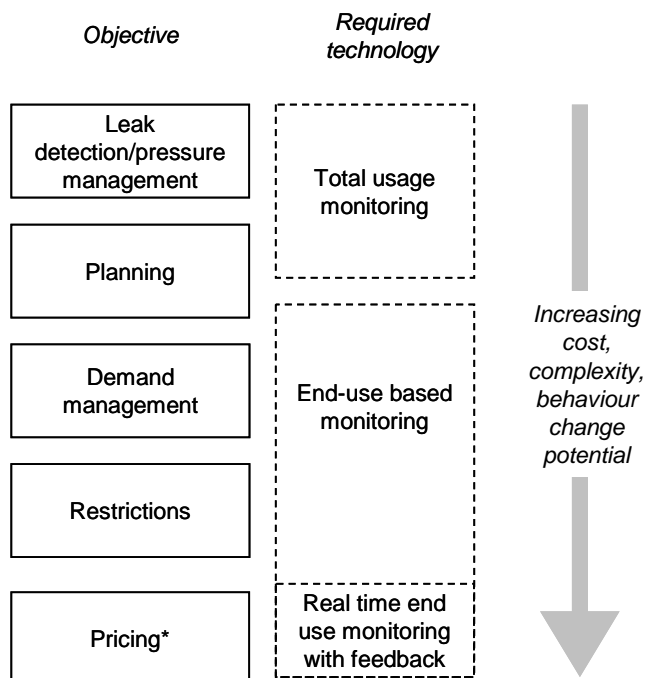

*\*Note pricing options require technology on all homes, not only a sample*

“Total usage monitoring” refers to measurement of water use for the entire residential property typically using meters at the property boundary. The frequency of sampling may be high but there is no need to gather information about how or where in the house the water is being used. Depending on the type of meter installed, a standard household meter will likely be sufficient for total usage monitoring. Rather than investing in new meters, you may like to use your budget to purchase data loggers, data transfer equipment and analysis software.

“End-use based monitoring” refers to water use measurement that separates volumes of water used by end-use. That is for each water using fixture, or appliance in the house, the volume of water used by that specific end-use can be quantified. You can gather this kind of information by metering specific end-uses or by installing metering systems which collect sufficient information for each water use event (e.g. flow and pressure) to enable identification of different end-uses.

“Real-time” monitoring extends the end-use approach to include rapid (real-time) analysis, interpretation and presentation of data (water volumes) by end-use to provide immediate customer feedback and enable householders to alter their behaviour. Real time end-use monitoring has not been possible on any significant scale to date, but is likely to be an area of future innovation. Real time monitoring with feedback could be particularly useful in the design and implementation of restrictions, during periods of rationing, or in the design and implementation of end-use based approaches to pricing.

A selection of available representative technologies are summarised in Table 3. See Appendix 3 for a list of manufacturers and their websites.

**Table 3: Summary of available end-use measurement technologies**

Technology	Data capture		Data transfer	Data analysis	Capabilities	Constraints	Indicative Costs
	Meter	Logger					
Global Water CZ2000 Smart Water Meter	✓	✓			Combined wireless flow meter and data logger. 10 pulses/Litre. Battery powered. Manual, radio and phone line data transfer capabilities.	No Bluetooth. Untested at large scales.	Meter costs AU475, installation costs AU100, operation/data transfer costs AU374
Global Water data transfer and analysis			✓	✓	Data transfer by radio (GPRS) or internet (landline/wireless) to central data server. Web based access with user name and password available for data analysis at a cost, although it is possible to analyse your own data.	Sim card required for mobile transfer. Modem required for internet transfer. No bluetooth.	Cost of access to web based analysis US350 per year
Manuflo Actaris CT5-S-B Flow Meter	✓				72.5 pulses/Litre. No power needed. ~2% meter accuracy.		AUD200-300
Monatec Monita R Series data logger		✓	✓		Automatic meter reading logger. 5 second interval readings. Battery powered. Manual, radio and phone line data transfer capabilities.	No Bluetooth. Teething issues with data transfer software.	AUD500-600
Monatec Monita D Series data logger		✓	✓		Manual meter reading logger. 5 second interval readings. Battery powered.	Manual download. Long processing time to analyse events.	AUD400
Landis and Gyr Ultrasonic Flow Meter	✓						Expensive

Technology	Data capture		Data transfer	Data analysis	Capabilities	Constraints	Indicative Costs
	Meter	Logger					
Elster Meter and Pulse	✓				Meter reads 1 pulse every 5L.	Meters read only 1 pulse every 5L so have limited usefulness.	AUD77 for meter AUD33 for pulse total AUD110
Great Plain Industries Turbine Flow Meters	✓					Poor resolution in low flow rates which turbine meters tend to have is not adequate for disaggregation purposes and end-use metering.	NZD250-NZD920 plus output unit NZD330
Nutating Disc Meters (manufacturers include ManuFlow, AMS Instrumentation and Calibration, BadgerMeter)	✓				Nutating discs: Best for flow rates between 1.5L/ min to 75L/ min Best to use a pulse output of 72.5 pulses per litre Slightly low pressure drop Electromagnetic meters: Best for low flow ranges <1.5L/ min Requires power supply		Rotary piston flow meter low resolution pulse AUD169 2 pulses/L AUD289 1 pulse/5L
Rosemount 8712D Magnetic Flowmeter	✓					Mains powered so can't operate during blackouts.	
Brainards Meter Master data loggers		✓			Records data at 10 second intervals.		USD2495 per unit
Aquacraft Trace Wizard analysis software				✓	Data storage and analysis. Can achieve 1 second intervals.	Must be used in conjunction with Microsoft Access. Difficult to separate similar end-use events that occur simultaneously.	USD1499

Technology	Data capture		Data transfer	Data analysis	Capabilities	Constraints	Indicative Costs
	Meter	Logger					
WrC Identiflow software				✓	Identiflow is a web based analysis developed by WrC. Identifies water end-uses through signature analysis.	Data analysis likely to rely on sending to WRc.	
Gemini Tiny Tag data logger		✓	✓	✓	Battery operated system capable of capturing, transferring and viewing data. For an additional cost the package comes with Windows based software to view flow data.  Memory capacity of 16,000 readings. Records down to 1 second intervals.	Manual download of information to laptop required. Battery power may be limiting in some circumstances.	AUD385 for data logger and AUD150 for software
USUS transfer and analysis package		✓	✓	✓	Radio (GPRS) / mobile (CDMA, GSM) / Satellite / internet to central data server.  Web-based access with username and password to access real-time data.		12 month lease \$700. Installation \$200. Communication \$60. Website design and support for 12 months \$500.  Monthly fees reduced for longer leases. Can purchase hardware and only pay monthly web access support.



Technology	Data capture		Data transfer	Data analysis	Capabilities	Constraints	Indicative Costs
	Meter	Logger					
Watersave Australia WaterGuard	✓	✓	✓	✓	Reads data 1-30 mins. Radio (GPRS)/mobile/ internet (modem or wireless connection)/ bluetooth. WaterGuards can detect leaks, can cut off water. Web-based access. WaterGuard Management System uses free Google Analytical software. Mains powered with battery backup.	Need to change software programming to get down to 10 secs, only viable for company if large purchases. Need pulse probe monitors (meters) to read water flow and send to logger.	
Wellspring Wireless Metering	✓	✓	✓	✓	Less complex analysis required when individual end-uses metered	Current version difficult to operate	
Waitek Shower Monitor		✓			Measures durations, flow rates accuracy $\pm .3$ LPM and temperatures (10 to 45° accuracy $\pm .3^{\circ}\text{C}$ )	Manual download. Shower timer appearance constant reminder that measurement is taking place may influence behaviour	AUD150

### 3.4 Choose your sample size

Selecting an appropriate sample size for your study is essential to ensure findings are representative. Variations in your chosen sample size will produce different results. Your choice of sample size will depend on your objective, data needs and financial resources.

This section identifies key issues for further consideration, detailed approaches for sampling can be found in Dziegielewski et al. 1993.

#### Key questions

Do you know your unit of analysis? (total water volume per house, specific end-use)

Have you defined your population clearly?

Can you identify sources of variation and quantify them?

The sampling process is conceptualised by the following stages:

1. Determine unit of analysis
2. Define population
3. Specify the level of error acceptable and confidence interval (for example acceptable error of 5% with 95% confidence interval)
4. Identify factors that may introduce confounding and variation
5. Choose sampling methodology
6. Calculate sample size
7. Prepare sample frame
8. Implement the sampling plan

#### *3.4.1 Determine unit of analysis*

The unit of analysis is generally specified in the study objective (see 3.1), at this point in the study ensuring that this is explicit will aid delivery of a successful study.

If the study is interested in the total volumes used then the unit of analysis may be the daily/monthly consumption. However if the study is interested in the end-use then the unit of analysis may likely to be the water use signature for a given use. Whatever the objective ensure clarity for the unit of analysis. There are a number of important questions to be clarified here including what is of interest and for how long should it be measured to provide the data needed?

#### *3.4.2 Define the population*

The study population may be all clients connected to the water network or interest may be in a particular subset. This must be clearly defined.

#### *3.4.3 Specify the level of error acceptable and required confidence limits*

This step will help focus the study, it is here that simple calculations can save considerable time and effort (see box on Melbourne Case Study). The level of error expected from the sample should be specified and the confidence required stated. Lowering the acceptable error and raising the confidence limits will both increase required sample size. It is for the study

proponents to decide what confidence they require from the data collected and subsequent analysis and what tests may be required during the analysis. There will be trade offs between larger samples and the additional accuracy relative to the costs.

#### *3.4.4 Identify factors that may introduce confounding and variation*

This stage is where some careful research is carried out to better understand what is known of the population (and how similar the populations of previous studies are, and hence the likely applicability of their findings). Reviewing existing in-house or external reports will aid in the identification of possible confounding factors. A confounding factor is any factor not considered that may mask true results. There should be a thorough interrogation of the population for systematic differences likely to result in different readings and therefore lead to high variability.

Examples of where variability may be found include:

- owner occupant status;
- number of occupants in the home;
- single-residential versus multi-residential;
- household size;
- age of the building;
- geographical location
- seasonal variation; and
- income levels and other socio-economic variables.

#### *3.4.5 Choose sampling methodology*

Consider two sampling methodologies, random sampling and non-random sampling. In random sampling every unit within the population has a known chance of being sampled. However this is not the case with non-random sampling. Most critically while non-random sampling methods may often appear less costly there is no way of calculating sample error while with random methods there has been a great deal of work done on calculating probable error due to sampling. Non random methods are not recommended in general.

Sampling methods include the following: (see Dziegielewski et al. 1993)

- simple random sampling
- systematic sampling
- sampling with probability proportional to size
- stratified sampling
- cluster sampling
- multi-stage sampling
- multi-phase sampling

Of these simple random sampling and stratified sampling are the two most popular methods. Stratified sampling allows the researcher to identify and cater for strata in their population that might otherwise lead to inclusive results due to high variability and also enables efficiencies in sampling. Another popular method is cluster sampling which may appeal due to being able to select samples which are geographically clustered. Care should be taken to

account for geographic variation. This method often leads to higher variation therefore requiring larger samples for similar results from other methods.

**3.4.6 Calculate sample size**

The sample size of a survey is impacted by two main issues; the inherent variability (both systematic and random) in the population and budget. Once you come to terms with these issues calculating sample size is a straight forward step. Clearly the previous steps must have been correctly completed and the sample frame must be drawn to be representative of the population. The law of large numbers and central limit theorem take care of some of the insecurities of smaller sample size however all else being equal a large sample provides greater precision. The cost of the study will be the cost of technology/analysis per house multiplied by sample size.

**Case study: Melbourne sample sizes for indoor and outdoor end-uses**

Within the Melbourne context, this case study develops an approach to experimental design, including selection of sample size, that can be used to meet end-use planning objectives.

The approach to sampling which is being proposed is informed by the Melbourne context. Whilst detailed analysis of end-uses have been undertaken in the Yarra Valley Region (Roberts, 2005), there remains work to be undertaken to use innovative approaches to end-use measurement to quantify representative data across regions in Melbourne with increased precision and accuracy.

In considering the sampling regime, the composition of the dwellings in Melbourne (and in the different retail areas of City West Water, South East Water and Yarra Valley Water) needs to be considered.

A breakdown of the projected dwelling numbers and their type is taken from the Melbourne End-use Model and shown in Table 4 below. This shows that the largest absolute number of multi-unit dwellings are in the South East region (yet they only represent 18% of the region's dwellings), whilst City West as a region has almost 30% of dwellings as multi-unit (although this region contains the smallest number of dwellings overall).

**Table 4: Composition of dwelling types for residential customers in each Melbourne Region**

Year 2005/06	Detached		Multi-unit (apartment)		Total
City West	198,000	71%	81,500	29%	100%
South East	458,500	82%	98,000	18%	100%
Yarra Valley	530,000	90%	61,000	10%	100%
Total	1,186,500	—	240,500	—	1,427,000

To gain a representative sample of users across Melbourne, it is proposed that blocking be undertaken according to larger and smaller single residential dwellings and also to multi-unit dwellings.

The regions and end-uses are shown in Figure 4. Note that the current end-uses in the Melbourne End-use Model are 'required services' (namely, for lawn and garden watering, for pool filling, car washing, hosing down and other), whereas for innovative end-use analysis there may be the chance to identify specific water-using technologies (namely,

sprinklers, hoses, spray guns, taps, drip systems) although this technology is only in prototype stage. Currently between technologies and required services there is a mix of direct mapping (i.e. all drip systems are used for garden watering) and indirect mapping (i.e. hoses map to many services and could be used to both water lawns and gardens as well as fill pools, wash cars etc). This may provide a basis for re-examining the parameters used in the end-use model.

**Figure 5: Regions, dwelling types and end-uses**



### Assessment of statistical significance and approach

The approach to designing a study which enables statistically significant results to be used in end-use planning needs to consider:

- how much improvement in parameter estimates for the end-use model are being sought
- how much more of the conservation potential can be tapped with 'real-time' feedback on end-uses.

In turn, the ability to address these questions depends on the trade-off established between

- required functionality / accuracy
- costs of data collection (capital and on-going)
- sample size
- duration of sampling regime.

Current gaps in data will also contribute to priority setting (for example- benefits arising from a focus on large single residential dwellings as these are large users and outdoor water usage is still to be better understood, however, multi-unit dwellings are currently also

poorly understood, although they represent a smaller component of poorly understood water usage than outdoor water use).

The approach to calculating sample size has been to use a randomised complete block design considering regions separately and running separate experiments for "large dwellings", "small dwellings" and "multi-units". The difficulty in estimating sample-size upfront comes from a lack of detailed understanding of the variability of data in the population and that which can be detected accurately with the equipment. The REUMS in Yarra Valley can be used as an *initial* estimate of variability in the population for specific end-uses.

### Summary table of sample sizes

All sample sizes are calculated with a power of 0.95 and a significance level of 0.05 – both can be relaxed to reduce the sample size required at the expense of certainty of results.

The variability of data shown in Table 5 have been modelled based on the observed variability in clothes washer volumes in the YVW 2004 REUMS study (p.38) where the average was 143 L and the standard deviation was 54 L (hence variance 54 squared = 2916 or approximately 3000). The interpretation of the figures is consequently that if we aim for a moderate precision, that is, to detecting a 20 L difference between regions (YVW, CWW, SEW) for average washing machine volume of 143L, then 300–400 samples will be required.<sup>2</sup> This will depend if clothes washers are one of six end-uses we wish to detect (in which case the sample will be approximately 300) or if it is one of 16 end-uses we wish to detect (in which case the sample will be approximately 400).

With reference to Figure 4, seeking to discern between only six end-uses would correspond to aggregated categories (i.e. outdoor, washing machines, dish washers, toilet, shower, other indoor) whilst discerning between 16 would refer to all end-uses and their specific sub-classifications. Similarly if we wish to detect a smaller absolute difference (i.e. higher precision or a 10 L difference between regions), then the sample size increase dramatically to 1,200–1,700, whilst if we are content with lower precision and detecting a difference of 30 L, then approximately 130–180 samples are needed.

**Table 5: Sample sizes for clothes washing data (assumed representative of indoor water use)**

	How many end-uses do you want to discern?			
	6 end-uses		16 end-uses	
Higher precision	Want to detect signal of 10 L	Given a variance of 3,000	Want to detect signal of 10	Given a variance of 3,000
	Requires sample size ~1,200		Requires sample size ~1,700	
Moderate precision	Want to detect signal of 20 L	Given a variance of 3,000	Want to detect signal of 20	Given a variance of 3,000
	Requires sample size ~300		Requires sample size ~400	
Lower precision	Want to detect signal of 30 L	Given a variance of 3,000	Want to detect signal of 30	Given a variance of 3,000
	Requires sample size ~130		Requires sample size ~180	

It is assumed that the variability in clothes washer data is representative of the variability in

homes, one for smaller homes and one for multi-units, then a larger sample size would be used in the larger home study which is likely to have much greater variability in outdoor water use. First, this requires a better understanding of outdoor water use variability.

Using the data from the YVW 2004 REUMS study (p.16) the standard deviation for outdoor water use is estimated at 400 L giving a variance of 160,000. This means that to detect a difference of 50 L in average daily outdoor water usage between regions (higher precision), then 2,500–3,500 samples are required as shown in Table 6, depending on whether six or 16 end-use categories are used. Being content with only detecting as significant a difference between regions of 100 L (moderate precision) requires a sample size of between 600–900. Higher required precision increases sample size more dramatically than increasing end-uses requiring detection.

**Table 6: Sample sizes for outdoor water use**

	How many end-uses do you want to discern?			
	6 end-uses		16 end-uses	
Higher precision	Detect 50 L	Variance 160,000	Detect 50	Variance 160,000
Sample size	~2,500		~3,500	
Moderate precision	Detect 100 L	Variance 160,000	Detect 100	Variance 160,000
Sample size	~600		~900	

### 3.4.7 Prepare sampling frame

A sampling frame is a comprehensive database representative of the population from which samples are drawn. Ideally the frame would include all households and the customer records database will be available to assist with preparation and selection of a sampling frame. Methods of customer contact and communication should also be developed and tested in a pilot.

### 3.4.8 Implement the sampling plan

Sample as per the method chosen and begin the study. As a check it is useful here to ensure the sample is in-fact representative of the population as planned. Manage on-going communication with participants.

## 3.5 Consider constraints

In practical terms, the implementation of a preferred end-use measurement study that meets desired objectives using appropriate technologies and sample size will be subject to practical constraints. Common constraints include budgetary constraints, available time and human resources with relevant experience and expertise to oversee the project.

The resources for and constraints on your study will shape the parameters of your study. If you have a smaller budget or limited time, certain aspects of the study may need to be refined. The aim of this section is to explicitly identify constraints and prompt a reconsideration of the ideal study design, to then consider what can be achieved within the constraints, whilst maintaining a clear understanding of what resources would be required to fully meet the desired objective. The ordered questioning of "what is the best imaginable study....followed by....what can I afford" is in deliberate preference to "what quality of study can I get for my money?". The aim of this Guidebook is also to help articulate the relationship

between study value (in terms of the richness of information delivered) and costs (technology and sample size) and the trade-offs involved in executing smaller studies.

Key questions

What is the available budget for your study?

What human resources are available for your study?

What human resources are available in the long term for on-going studies?

Are there time and seasonal limitations on your study?

Is the geographic scope of your study limited?

Is technology available for the specified needs ?

An indicative budget, timeline and should be determined and then reviewed in the context of relevant constraints.

A typical project plan would involve the following components:

- Scope
  - Articulate the objectives of the project, data requirements, sample size and character (e.g. random, stratified) and how the proposed study will meet its objectives.
- Budget
  - From the costs of individual technologies or surveys, outline the sample size and human resource overheads including management costs and contingencies.
- Timeline
  - Note the length of study, planning phases, data collection phases, analysis phases, monitoring and reporting phases including critical paths. A Gantt chart could be helpful.
- Resources
  - Assess equipment and human capital within the organisation and participants in the study.
- Communication plan
  - Plan interactions with customers and letters of invitation to participate. Assess issues relating to privacy and storage of data.

The preparation of such a plan provides a suitable starting point from which to consider potential constraints on your study. If only a limited budget, or limited time frame are available to complete the study, objectives, scope and study design will need to be refined as appropriate.



The trade-offs associated with undertaking studies with limited resources, will also depend on what previous studies have been undertaken and what additional research questions are required to be answered.

*Are you seeking to identify many end-uses with limited sample size or to understand one end-use in more detail?* This trade-off will be informed by the existing body of literature. For example, if little end-use work had been done previously, an initial comprehensive estimate – however limited – may be preferable to details for one part of the picture only. Alternatively, if the results from other recent studies can be used as an initial guide, then effort could be focussed on filling remaining gaps in more detail – e.g one end-use of particular interest. If seeking to focus specifically on understanding one end-use in more detail, additional benefits can be achieved by coordinating the research program with other utilities to avoid duplicating work and ensure investigations are complimentary.

*Do you intend to combine stock surveys with end-use monitoring?* In areas where stock surveys have already been undertaken, specific monitoring of end-uses can place in context the accuracy of the stock surveys.

*Will you manage the project internally or outsource?* Internal management can help build organisational capacity in end-use measurement studies.

*Do you plan to regularly update the results of the study?* The need for regularly updating end-use results will depend in part on underlying changes to stocks of water using equipment, the introduction of new technologies and changes to water using behaviours, for example following the lifting of restrictions.

*Do you plan to undertake a snapshot or longitudinal study across seasons or years?* The magnitude of seasonal and tourist variations in water consumption will vary between jurisdictions.

*What is the profile of end-use measurement studies within your organisation and how is this related to the current supply-demand balance?* It may be easier to make a case for additional end-use understanding when supply-demand balance is tight and management focus is centred on better understanding the basis for demand forecasts

The next step following consideration of constraints, is to undertake a subsequent iteration of the study design cycle as outlined at the beginning of Section 3. When you achieve a study design which meets with your constraints, the next phase is implementation and execution of the study. Tips and tricks for the implementation phase are discussed further in Section 4.

## 4 Tips and tricks for implementation

This section outlines practical components associated with end-use measurement studies to complement the framework outlined in earlier sections of this Guidebook. It is intended to assist with the successful implementation of end-use research studies.

A paper by Cordell et. al. (2003) provides a helpful list of things to do and not to do with respect to the collection of residential end-use data from primary resources, covering both surveys and the use of meters for data collection.

Successful implementation of end-use measurement studies benefits from a mix of well resourced project planning, flexibility and attention to detail.

Areas to consider include:

- Project management
  - End-data is valuable. Discussing data needs with different departments in your organisation prior to undertaking the study can help to really determine what will be most beneficial, and who will use the data. In some cases, a small amount of additional planning could fulfil complementary objectives within the organisation - e.g. will you need to fit new meters to homes to collect the data? - you could find out what is happening with meter replacement programs to target meters needing replacement anyway, however be conscious of any bias that is introduced in sample selection.
  - Draw on the experience of other research studies by contacting other researchers prior to undertaking the study to reflect on their experiences.
- Stakeholder consultation
  - Consider stakeholders internal and external to the organisation.
- Obtaining participants
  - Think through privacy issues and obtain permission from participants at an early stage.
  - Consider carefully the sampling regime (stratified, random) and biases that may be introduced through self selection.
  - Incentives may be a useful way to obtain participants in a larger study, but it is important to note that they may bias sample selection and results.
- Pilot study
  - Undertaking a pilot study is useful, especially for testing of new technologies or research methods. It may not be required when doing a repeat study to update older data.
  - The pilot study will uncover issues that could be much harder to manage if they present *en masse* as part of a larger study, e.g. problems with the installation of meters or data collection, problems obtaining participants.
- Hotline for dealing with technical and customer issues
  - Setting up a hotline can be a helpful way to keep participants at ease, be sure to respond promptly.

- Privacy issues
  - Consult residents regarding their attitudes to privacy, data collection and use
  - Make residents aware of the level of detail of data which will be collected and ensure that they do not get any "surprises" associated with the data collection detail.
  - Keep customers' data securely stored.
  - Aggregate final data and keep participants up to date with the results of the study, why it is important and how the results are being used. Consider also how the forms of communication with participants may influence their water-using behaviour during the study period.

### **Case Study: *Gold Coast Watersaver End-use Project***

Griffith University and Gold Coast Water (GCW), Queensland, have commenced an end-use water consumption study (2008). The study will investigate end-use water consumption in 200 residential homes with the use of high resolution water meters (Actaris) and data loggers (Monatec) with manual download via laptop.

The primary objectives of the study are to:

- Develop an end-use water consumption model for the Gold Coast;
- Measure the water savings attributed to dual reticulated systems;
- Determine the effectiveness of education as a demand management strategy; and,
- Explore community perceptions, attitudes and behaviours and how these relate to end-use water consumption.

This project will enable GCW to verify assumptions made in long term planning, will improve forecasting, will enable evaluation of the effectiveness of demand management.

Lessons from this study include using multi-channel loggers to collect data from potable water meter and recycled water meter simultaneously to minimise costs.

## 5 Concluding thoughts – future opportunities for end-use metering

The purpose of this Guidebook is to present, using a step through approach, the fundamentals of end-use data collection. In developing this Guidebook, there is recognition of the sheer variety of metering and data capture / manipulation solutions and technologies on the market today. Improvements in metering, communication and data analysis in recent years have contributed to this proliferation of technologies and in this regard, aspects of the Guidebook can only hope to capture the current state of the art.

Sample size for end-use measurement studies remains a difficult issue to resolve in terms of balancing the statistical certainty with the overall costs and logistics of the metering program. This is one area where future opportunities (through economies of scale and new technical developments) will see increasingly large measurement studies – and in doing so, will drive further changes to the way water is managed in Australian cities. Low resolution data collection remains a rate-limiting factor in the adoption of more innovative approaches to water pricing and trading. While new technologies are emerging, further work is required in the development and commercialisation of innovative meters and in developing processing algorithms to minimise data handling and processing costs.

With further development, the monitoring and measurement of water can be integrated with that of other utilities (such as energy and gas). This process is being driven by the need for more accurate data on water use by end-use and at the same time is being led by the promise of reform and innovation.

This Guidebook provides direction for this transition – for water planners and managers – based on research undertaken with the support of the Smart Water Fund. In the future, it is easy to imagine widespread rollout of high-tech metering equipment connecting data to the householder and the utility as well as informing their decisions on water use and planning for that use in a highly dynamic and effective way. Yet there remains further development in order to realise this sort of vision – this development will come through new metering studies that generate additional data and in the way that this information is interpreted and utilised. In this way, the direction and guidance provided by this report that will support these new metering studies has the implicit objective of realising a ‘smarter water future’ – smart in the way water use data is collected; and smart in the way the data informs planning and management of this fundamental resource.

## References and further reading

- Australian Bureau of Statistics 2002, *Environmental Issues: People's views and practices*, Report Number 4602.0.
- Beatty, R. & Maddaus, B. 2002, *Demand Side Management Least Cost Planning Decision Support System: User manual - Version 12*, NSW Department of Land & Water Conservation.
- Britton, T., Cole, G., Stewart, R. and Wiskar, D. 2008, Smart metering as a tool for the remote diagnosis of leakage in residential households. Efficient 08, Gold Coast 31 March – 2 April 2008.
- Coombes, P.J., Argue, J.R. & Kuczera, G. 2000, 'Figtree Place: a case study in water sensitive urban development (WSUD)', *Urban Water*, vol. 1, no. 4, pp. 335-343.
- Cooney, M. 1994, 'A Water Utilities AMR Decision From Start to Finish', *Journal of New England Water Works Association*, vol. 108, no. 4, pp. 271-276.
- Cordell, D.J., Robinson, J.E., Loh, M.T.Y. 2003, 'Collecting Residential End Use Data from Primary Sources: Dos and Don'ts', *Efficient 2003: Efficient Use and Management of Water for Urban Supply Conference*, Tenerife, Spain.
- Country Energy, 2005, 'Smart Metering Trial Promises Savings' *EWON News*.
- Day, D. & Campbell, S. 2002, *Evaluation of the Demand Reduction for the 'Every Drop Counts' Residential Retrofit Program (for Sydney Water Corporation)*, Institute for Sustainable Futures, UTS, Sydney.
- Day, D., Sarac, K., Carew, A. & White, S. 2000, *Evaluation of the Rous Regional Demand Management Strategy*, Institute for Sustainable Futures.
- Day, D. & White, S. 2000, *Evaluation of the Smart Showerhead Program (for Sydney Water)*, Institute for Sustainable Futures.
- Dziegielewski, B., Kiefer, J.C., Opitz, E.M., Porter, G.A., Lantz, G.L. 2000, *Commercial and Institutional End Uses of Water*, AWWA Research Foundation and the American Water Works Association.
- Dziegielewski, B., Opitz, E.M., Kiefer, J.C., Baumann, D.D. 1993, *Evaluating Urban Water Conservation Programs: a procedures manual*, American Water Works Association.
- Economic Regulation Authority (WA) 2004, *Inquiry on Urban Water and Wastewater Pricing: Issues Paper*, Perth.
- Erlanger, P. & Neal, B. 2005, *Framework for urban water resource planning*, Water Services Association of Australia: Occasional Paper No. 14, Melbourne.
- Essential Services Commission of South Australia 2005, *Inquiry into the 2006–07 water and wastewater pricing processes: issues paper*, Adelaide.
- Fane, S.A. 2005, 'Planning for Sustainable Urban Water: systems-approaches and distributed strategies', PhD. thesis, University of Technology, Sydney.
- Foody, C. 2006, 'Domestic Potable Water Demand on the Central Coast, New South Wales', University of Newcastle, NSW.
- Fryer, J. 1999, 'Demand Elasticity During a Drought', *AWWA Conference Proceedings: CONSERV99*, Monterey, California.
- George Wilkenfeld and Associates 2003, *A mandatory water efficiency labelling scheme for Australia*, Department of Environment and Heritage.
- George Wilkenfeld and Associates 2004, *Regulation impact statement: Proposed national system of mandatory water efficiency labelling and standards for selected products*, Department of Environment and Heritage.

- Gleick, P., Cooley, H. & Groves, D. 2005, *California Water 2030:an efficient future*, Pacific Institute.
- Hajkowicz, S., Young, M., Wheeler, S., Hatton MacDonald, D. & Young, D. 2000, *Supporting Decisions: Understanding Natural Resource Management Assessment Techniques*, CSIRO Land and Water.
- Hauber-Davidson, G. and Idris, E. 2006, 'Smart Water Metering', *Water: Journal of the Australian Water Association*, vol. 33, no. 3, pp. 56-59.
- Heinrich, M. 2006, 'Residential Water End Use Literature Survey' *BRANZ Study Report 149*, Judgeford, New Zealand, Branz Ltd.
- Heinrich, M. and Stoecklein, A. 2006, Interview with Matthias Heinrich and Albrecht Stoecklein about the New Zealand Residential Water Use study. Interviewed 8th August 2006.
- Idris, E. 2005, 'Smart Metering: A Significant Component of Integrated Water Conservation Systems' *Young Water Professionals Conference*, Sydney.
- ISF 2003, *Gold Coast Water Emergency Bulk Water Supply Planning: the potential of demand management*, Institute for Sustainable Futures.
- ISF 2005, *A Review of Water Efficiency Programs in Western Australia: Towards a Strategy for Best Practice*, Water Corporation of Western Australia.
- ISF and CSIRO Urban Water 2001, *Melbourne End Use and Water Consumption Influences Study*, Retail Water Companies for the Water Resource Strategy Committee for the Melbourne Area, Melbourne, VIC.
- Krannich, R., Keenan, S., Walker, M. & Hardesty, D. 1996, 'Social Implications of severe sustained drought: case studies in California and Colorado', *Water Resources Bulletin*, vol. 31, no. 5, pp. 851-865.
- Loh, M. T. Y. and Coghlan, P. 2003, *Domestic Water Use Study In Perth, Western Australia 1998-2001*. Water Corporation. Perth, Western Australia, Water Corporation: 36pp.
- Lundie, S., Ashbolt, N., Livingston, D., Lai, E., Kärrman, E., Blaikie, J. & Anderson, J. 2005, *Sustainability Framework: Methodology for Evaluating the Overall Sustainability of Urban Water Systems*, University of New South Wales, Centre for Water and Waste Technology (School of Civil and Environmental Engineering).
- Maheepala, S. 2003, 'Assessing climate change implications for urban water supply planning', *Australian Water Association Regional Conference*, Lorne, Victoria.
- ManuFlo, 2006, "ManuFlo Flow Measurement Products." Retrieved August, 2006, from <http://www.manuflo.com/>.
- Mayer, P. W. 2006, Interview about Trace Wizard software, data loggers and Aquacraft Inc. Interviewed July 2006. <http://www.aquacraft.com/>.
- Mitchell, C., Turner, Andrea., Cordell, Dana., Fane, Simon., White, Stuart. 2004, 'Water conservation is dead: long live water conservation', *2nd IWA Leading Edge Conference on Sustainability in Water Limited Environments*, IWA, Sydney, Australia.
- National Energy Action, 2006, 'Cutting Energy Bills: Trial of Innovative 'Smart Meters' Starts' UK Climate Change and Environment, Media Release 24/04/2006.
- Neptune Technology Group, 2003, 'Hybrid AMR System – It Takes Vision and Planning But It Can Be Done', Neptune Technology Group Inc.

- Olaf Nelson, J. 1999, 'Residential end uses of water and demand management opportunities' *International Symposium on Efficient Water Use in Urban Areas - Innovative Ways of Finding Water for Cities*, UNEP.
- Omega, 2006, *Transactions in measurement and control. Volume 4 flowmeters*, www.omega.com
- Owen, G. and War, J. 2006, 'Smart Meters: Commercial, Policy and Regulatory Drivers' *Sustainability First*: 54.
- Queensland Competition Authority 2000, *Statement of regulatory pricing principles for the water sector*, Brisbane.
- Reidy, C. 2003, 'Vintage Stock Modelling of Domestic Appliances: Dealing with Uncertainties', *3rd International Conference on Energy Efficiency of Domestic Appliances and Lighting*, Turin, Italy.
- Roberts, P. 2004, *Yarra Valley Water: 2003 Appliance Stock and Usage Patterns Survey*.
- Roberts, P. 2005, *Yarra Valley Water: 2004 Residential End Use Measurement Study*.
- Sands, O. 2007, 'The swing to smart solutions', *Water21: Magazine of the International Water Association*, April.
- Sarac, K., Day, D. & White, S. 2002, 'What are we Saving Anyway? The Results of Three Water Demand Management Programs in NSW', *Proceedings of the International Water Association Congress*, Melbourne.
- Scottish Water, 2006, 'Scottish Water: Smart Metering: Internet-Based Reporting System for Water Consumption using Smart Data Loggers', retrieved 16 August, 2006, from [http://www.idswater.com/water/europe/Scottish\\_Water/Smart\\_Metering/11\\_0/g\\_supplier\\_4.html](http://www.idswater.com/water/europe/Scottish_Water/Smart_Metering/11_0/g_supplier_4.html).
- Snelling, C., Mitchell, C. & Campbell, S. 2005, *Melbourne End Use and Options Model: Volume 2 - Manual*, Institute for Sustainable Futures.
- Turner, A., Campbell, S., White, S. 2003, 'End Use Modelling & Water Efficiency Program for Arid Zones: The Alice Springs Experience', *Efficient 2003: Efficient Use and Management of Water for Urban Supply Conference*, Tenerife, Spain.
- Turner, A., White, S., Beatty, K., Gregory, A. 2005a, 'Results of the Largest Residential Demand Management Program in Australia', *International Conference on the Efficient Use and Management of Urban Water*, Santiago, Chile.
- Turner, A., Willetts, J., Fane, S., Giurco, D., Kazaglis, A., White, S. 2008, *Guide to Demand Management*, Institute for Sustainable Futures for the Water Services Association of Australia.
- White, S. (ed.) 1998, *Wise Water Management: a demand management manual for water utilities*, Water Services Association of Australia, Sydney, NSW.
- White, S., Robinson, J., Cordell, D.J., Jha, M. & Milne, G. 2003, *Urban Water Demand Forecasting and Demand Management: Research Needs Review and Recommendations*, Occasional Paper No.9, Water Services Association of Australia.
- Zhou, S.L., McMahon, T.A., Walton, A. & Lewis, J. 2000, 'Forecasting daily urban water demand: a case study of Melbourne', *Journal of Hydrology*, vol. 236, no. 3-4, pp. 153-164.
- Zhou, S.L., McMahon, T.A. & Wang, Q.J. 2001, 'Frequency analysis of water consumption for metropolitan area of Melbourne', *Journal of Hydrology*, vol. 247, no. 1-2, pp. 72-84.

## APPENDIX 1 PREVIOUS END-USE MEASUREMENT STUDIES

Jurisdiction and Study	Year	Outcomes	References
Bristol County Water Authority –UK Automatic Meter Reading Study	1994	Over 3600 Accessplus smart meter units were installed from 1989 to 1993 as part of a system wide AMR installation. The paper looks at the decision process through to the installation in over 33% of its authorised area.	Cooney 1994
American Water Works Association USA and Canada Residential Uses of Water Study	1996 - 1999	Water consumption patterns and demographic factors that affect water use in North American homes were analysed from 12 cities in USA and two cities in Canada. The project identified typical end-uses of water in single-family detached homes. Indoor water use was relatively stable across all households.  Meter Master data loggers were attached to 1,188 existing water meters in single-family dwellings recording flow rates at ten second intervals and analysed by Trace Wizard. The data loggers recorded water usage over a two week period in summer and two weeks in winter . The database was prepared in Microsoft Access with tables cross-linked with a Keycode to protect individual customer privacy (Olaf and Nelson 1999). 6000 surveys were conducted and the billing records of 12,000 households were analysed in addition to the data logging recordings. No home visits were conducted to reduce sampling bias from studying a group of volunteers .	Heinrich 2006
Toronto Water Canada	1997	Twenty-four households were monitored to determine water use and the effectiveness of water-saving devices. The City of Toronto wanted to understand how water was used for each end-use event (e.g. showering) and how often. A magnetic signal converter data logger was attached to each household's water meter with a software package that separated the flow trace data in to recognised end-use events. Monitoring occurred for a total of two seven day periods, one week before the water-saving devices were installed and one week after. Water consumption decreased by 66 Litres per capita per day after the water-saving devices were installed.	
Western Australia Water Corporation Perth Domestic Water Use Study	1998 - 2001	The Domestic Water Use Study (DWUS) collected data on household water usage and identified water usage patterns and trends. The study developed a demand forecasting model and a water use efficiency programme.  The pilot study monitored 120 single-residential homes over a 20 month period (November 1998 to June 2000) separated into three groups of high, medium and low socio-economic status. Monitoring relied on Meter Master data loggers to collect the data and Trace Wizard software to analyse it. An additional 600 homes were included in three questionnaire surveys that focused on appliance ownership, demographics and attitudes to water use. Participants were asked to phone in their water consumption each week. Each group of 40 households was located close together as zone metering was also used to assess water use during the study period.  Participants were required to keep a diary for the first four days where they recorded time of use for all end-uses. This data was used to calibrate against Trace Wizard. This was, however, a time consuming job to	Loh and Coghlan 2003



Jurisdiction and Study	Year	Outcomes	References
		<p>combine diary data with flow data in order to develop calibration plots for each end-use.</p> <p>Data loggers had to be downloaded, initially, every two weeks but with additional memory, capacity downloading was extended to six weeks which greatly reduced operating costs. The raw data from the data loggers were received as text files and so needed to be converted into a format that could be recognised by Trace Wizard. This required a custom data processing routine.</p> <p>The Water Corporation staff analysed the data using Trace Wizard. The data analysis phase was quite labour intensive. It was recommend one operator assess the entire dataset due to systematic errors adversely affecting the results if multiple operators analysed separate components of the data. Trace Wizard worked well for defined uses. Overlapping end-uses (such as simultaneous events of showering and taps turned on to wash hands) were more difficult to ascertain. Hand taps were very difficult to distinguish between kitchen, bathroom and outdoor use for example.</p> <p>The next phase of the project collected data from 279 multi-residential households. 124 of these multi-residential households had meters installed to monitor their water usage from September 2000 to November 2001, with the remaining 173 households answering questionnaires only. Metering of the multi-residential dwellings involved 26 duplex properties, 26 triplex properties, four to ten units (34 properties); more than ten (34 properties). This last category included some nine to ten high-rise apartments which were three to four storeys high at most. This component of the study could not work with the majority of multi-residential dwellings due to the cost of installing individual meters. The study group favoured public housing properties as they had all been individually metered. The study was unable to capture common area water use. More research is required to determine water use in multi-residential dwellings as there continues to be strong growth in this type of property.</p> <p>Baths and showers, and the washing machine had the highest consumption of water in both single and multi-residential dwellings. Toilet and tap use swapped positions of 3rd and 4th place in the two types of dwellings with more water being used by toilet flushing than taps in single-dwelling compared with more water used from taps than from toilet flushes in multi-residential dwellings .</p>	
Tampa Water Department Residential Water Conservation Study	2004	The study looked at the impacts from plumbing fixture retrofits in single-family residential dwellings. Data loggers monitored water use two weeks before and two weeks after the water-efficient devices were installed in 26 homes. Average household consumption dropped by 46%, from 796 L/p/d to 405 L/p/d	Heinrich 2006

Jurisdiction and Study	Year	Outcomes	References
Yarra Valley Water Victoria Residential End Use Measurement Study	2005	<p>100 homes had data loggers attached to their water meters and Trace Wizard was used to analyse data collected over a two week period in summer and a two week period in winter at five second intervals. Survey and billing data were also used to determine end-use consumption</p> <p>The project was able to discern end-uses. The shower (22%), washing machine (19%), toilet (13%) and taps (12%) had the highest water use for indoor consumption. Seasonal uses (which included outdoor irrigation, pool and spa) accounted for 25% of a household's water consumption.</p> <p>The project had problems with corrosion of monitoring equipment, and weatherproofing each installation has been suggested as a way of solving this. A CT5-S positive displacement flow meter from ManuFlo with a pulse output of 72.5 pulses per litre was suggested as the preferred equipment to use</p>	Roberts 2005 Heinrich 2006
Country Energy New South Wales Smart Electricity Meter Trial in Queanbeyan and Jerrabomberra	2005	<p>Country Energy trialled the use of in-house user-friendly smart meter technology so that customers could monitor their energy consumption and costs. 200 households in Queanbeyan and Jerrabomberra in south-eastern NSW (near ACT border) were involved in the study.</p> <p>The technology included an in-house display unit that received real time data about household energy consumption and provided pricing information to the customer. Householders adjusted their energy usage based on the price they observe on the display unit screen.</p>	Country Energy 2005
Wyong New South Wales Domestic Potable Water Demand on the Central Coast	2006	<p>A pilot study was conducted on a single residential detached household in Wyong Shire, NSW (two hours north of Sydney). Its aim was to determine the compatibility of Trace Wizard software with various water meters and data loggers that are easily purchased from Australian distributors.</p> <p>Data was collected before and after water efficient devices were installed in the single residential dwelling in order to measure any changes in water consumption. A Dynasonics Model TFLX Transit Time Ultrasonic Flow Meter was the initial water flow meter used. It was supplied and calibrated by an American supplier, Flow Line Options. Installation took approximately five minutes by a plumber. However, the flow meter produced unreliable data and so a Rosemount 8712D Magnetic Flowmeter System was used as an alternative and functioned successfully. The Rosemount consisted of a flow tube and transmitter, with a 240 volt mains power supply. The original council flow meter was removed for the test installation due to there being no space to clamp the flow meters on to the meter.</p> <p>A Gemini Tiny Tag data logger was used to record flow rates at 12 second intervals and manually downloaded each day onto a laptop each day which contained Gemini Windows-based software. Volume, peak flow rate and duration of each end-use water event were measured at the beginning of the study to enable the peaks in the flow trace to be attached to the correct end-uses. Trace Wizard had to be recalibrated to fit Australian data as the software uses a set of default parameters that are based on American homes. Undetermined water was less than 10%.</p> <p>The Rosemount 8712D Magnetic Flowmeter System would be best to run from a battery supply to increase system reliability so that data collection would not be affected during power outages.</p>	Foody 2006

Jurisdiction and Study	Year	Outcomes	References
		The Gemini Tiny Tag data logger was reliable and accurate but had a small memory capacity which meant it had to be downloaded each day. The memory capacity would have to increase for larger studies. This would improve the accuracy of data collection and simplify the flow trace analysis process.	
Scottish Water Internet Based Reporting System for Water Consumption Using Smart Data Loggers	2006	Scottish Water uses an internet-based reporting system, which shows recorded data in 15 minute intervals. Information is updated daily and can be viewed 24 hours a day, anywhere in the world using an internet connection and user password. Scottish Water provides an Automatic Meter Reading (AMR) service for customers with larger networks, and those who require multiple utility meters (or sensor outputs).	Scottish Water 2006
National Energy Action United Kingdom Energy Smart Metering Trial	2006	EDF Energy Smart Metering Trial will install electricity and gas smart meters into 3000 homes over a two year period. Some of the aims include gauging the amount of energy consumers will save by becoming more aware of their energy use. The smart meters will be monitored electronically (via remote access), with customer-friendly display units inside the homes of customers.	National Energy Action 2006
New Zealand Water End Use and Efficiency Project Branz Study Report	2007	<p>The Water End Use and Efficiency Project (WEED) was established to determine the amount of water used in New Zealand homes for each type of end-use, time of day and the duration of each end-use event, plus the behavioural and social drivers of end-users. The project is particularly interested in hot water and energy savings. The project is expected to be completed by March 2007.</p> <p>New Zealand does not meter most homes but has a fixed rate for water usage. However, Auckland, Nelson and Tauranga councils have begun metering homes. The residential water end-use study put data loggers in 13 homes across New Zealand in 2005 and used Trace Wizard to analyse the data.</p> <p>The team modified the data loggers (such as adding an extra chip) to increase storage capacity and the recording times to ten second intervals. With the storage capacity increased, the team was able to download data from the data logger once a month. The flow meter and data logger both ended up costing approximately NZ\$400 each.</p> <p>The project team found Trace Wizard was easy to use and easy to change readings from ten seconds down to five seconds. Initially they received help with the analysis from Aquacraft Inc., but soon analysed the data themselves taking a couple of hours to analyse a month's data.</p>	Heinrich 2006; Heinrich and Stoecklein 2006

## APPENDIX 2 END-USE MEASUREMENT METHODS

This section first describes the methods used to capture and store data from water meters together with other information useful in discerning end-uses in the home. General methods for data transfer and analysis are then explored in Sections A2.2 and A2.3.

### A2.1 METHOD OF DATA CAPTURE

The most suitable methodology for data capture is a trade off between cost and reliability of data. It depends on the technique used. In this sub-section on data capture, both automated methods for obtaining water usage (meters and data loggers) are discussed, as well as manual methods (household inspections). The collection of data not directly related to water flows but which assists to infer water usage is also discussed, for example electricity metering and discrete event registering.

#### Meters

Currently, water meters provide baseline information for water utilities on pricing, total volume of water usage and seasonal and hourly patterns in single-residential and multi-residential households (Cordell et al. 2003). There are several aspects of metering that require consideration in relation to this study:

- type of meter – what signal it produces as a potential input to the data logger
- frequency of output (e.g. pulses per litre)
- range of flow rates which can be measured, especially at low flows
- single meter measuring multiple end-uses versus dedicated meters for each end-use.

#### *Type of meter*

Common types of meters used to measure water flows include positive displacement meters, magnetic flow meters and ultrasonic flow meters. Magnetic inductive flow meters do not tend to cause a drop in water pressure as do positive displacement meters. A pressure drop makes discerning end-uses more difficult. Unfortunately, magnetic flow meters are expensive. The magnetic flow meters and ultrasonic flow meters both require a power supply, which contributes to their higher cost (Heinrich 2006).

Turbine or paddle wheel (positive displacement) meters produce a pressure drop across the meter, but have lower costs compared with magnetic flow meters.

#### *Frequency of output and range of flow rates*

A high-resolution water meter generates more than 20 pulses per litre. Cheaper water meters tend to generate fewer pulses per litre.

There are certain requirements for flow meters used in end-use studies:

- Ability to measure a range of flow rates. It is common for meters to measure between 3–80 litres per minute, however more expensive magnetic flow meters can go down to 1 litre per minute.
- Minimum or no pressure drop noticeable (a drop in pressure can affect the person's experience with the end-use activity, such as showering).

- Resolution of more than 20 pulses per litre (equipment ranges from 1 pulse per 100 litres to 1,000 pulses per litre, however if the pulse rate is too high, it can make it difficult for some loggers to pick up cleaning and reduces memory).
- The meter needs an output for logging pulses such as reed switches (Heinrich 2006).

Most water meters have small holes (covered by a rubber cap or such) or a jacket where a probe can be inserted or attached in order to pick up a magnetic pulse every time the mechanical wheel device turns in proportion to the volume of water passing through. Probes can be bought separately from the meter manufacturer (e.g. Elster, Davies-Shephard, ABB, Kent). It is important to specify the exact meter type. Probes pick up one turn of the wheel as an electric signal. It is also important to know the volume of water that one pulse (i.e. one turn of the wheel) represents. This depends on the size of the water meter. Common values are 1 L, 5 L or 100 L/pulse which are too coarse for end-use measurement, meaning meter upgrades are usually required (Hauber-Davidson and Idris 2006) for end-use analysis. Installing new meters also overcomes inherent inaccuracy with older meters.

### *Measuring one or more end-uses*

Different meter types can be used depending on whether seeking to monitor one or more end-uses, the two options being individual meters on each end-use or a single meter going to the home. The approach to discerning end-uses when a single meter is used is to measure the incoming water flow rate which can then be used to establish characteristic traces which can be associated with end-uses.

## Flowmeters

This section provides details of specific flowmeters which can be grouped as positive displacement meters, ultrasonic flow meters and magnetic flow meters.

### *Positive displacement meters*

Nutating disc meters and rotating valve flow meters continuously fill and discharge the measuring chamber. When the chamber is set in motion, the magnet rotates and the signal is picked up by an additional magnet or electronic sensor through the wall of the meter (Heinrich 2006a; ManuFlo 2006). An illustrative example of positive displacement meters is shown in Figure 6 below.

**Figure 6: Nutating Disc and Rotating Valve meters (Omega, 2006)**

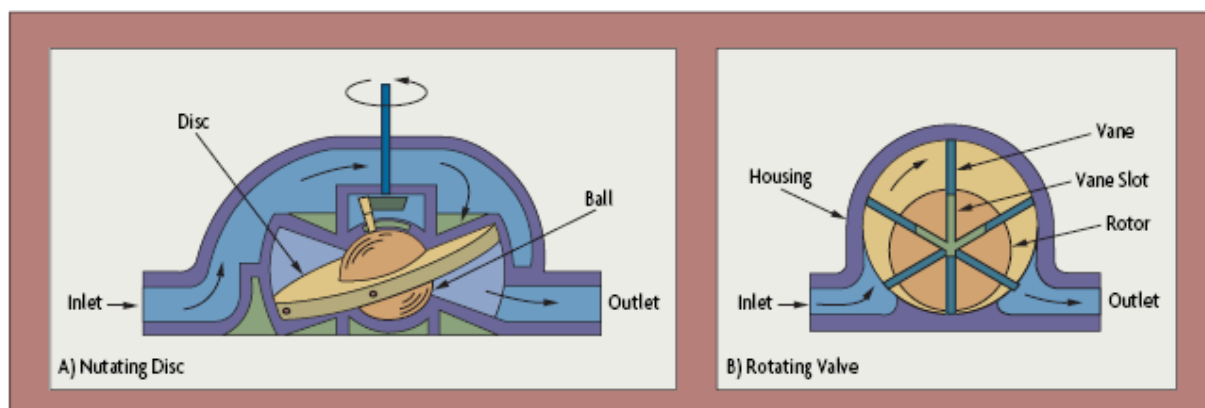

Issues:

- Nutating disc meters are best used for flow rates between 1.5 L/min and 75 L/min (Manu 2006).
- For flow rates below 1.5 L/min, electromagnetic meters are better suited, though they are more expensive (Heinrich 2006a; Manu 2006).

Nutating disc meters have been used in New Zealand to measure water consumption in residential households. Pulse rates of 70 or more per minute (flowing through with 20mm pipes) were found to be too high to count and so 25mm pipes were connected to the disk meters which improved readings (Heinrich 2006a; Manu 2006).

### *Ultrasonic Flow Meters*

There are no moving parts with ultrasonic flow meters. Two transducers transmit ultrasonic signals in and against the direction of water flow. The flow rate is determined from the difference in time between upstream and downstream measurements. (Dynasonics 2006; Landis and Gyr 2006).

Installation can take around 5 minutes by a plumber making it a good option for working with large samples. Ultrasonic flow meters can be clamped onto or replace existing mechanical flow meters. The flow meters need to be powered by means of a battery to avoid problems with blackouts.

The data collected by the ultrasonic flow meters can be read using a Windows®-based software utility that comes with the equipment.

Issues:

- Foody (2006a) found that the flow meter produced unreliable data during her research about smart meter equipment for water consumption in Wyong Shire. It was not known exactly what caused these negative spikes, and as it could not be rectified by the company, a magnetic flow meter was used as an alternative.
- She also noted that the ultrasonic flow meters used in her research had installation difficulties with space around water pipes and produced poor readings.
- Additionally, research undertaken by CSIRO Division of Industrial Physics in the mid 1990s focused on the use of ultrasonic meters as a replacement for the standard customer billing meter at the property boundary. The perceived advantage of the ultrasonic meter in this application was significantly increased accuracy – capable of measuring leaks at a rate of one drip every 5 seconds through a 20mm pipe. In attempting to develop a replacement for the billing meter, cost minimisation was a key component to this project. Identifying individual end-uses was not a focus.

### *Magnetic Flowmeter System*

A magnetic flowmeter system (for example the Rosemount 8712D) consists of a flow tube and transmitter, with a 240 volt mains power supply. Coils at opposite sides of the flow tube create a magnetic field. When water moves through the magnetic field. A voltage is created that is proportional to the flow velocity (Foody 2006a).

Magnetic flow meters do not tend to cause a drop in water pressure when installed in the feed line after the storage tanks. Another benefit is simple installation.

Electromagnetic meters are better suited to flow rates below 1.5 L/min (Manu 2006).

Issues:

- Magnetic flow meters are expensive (\$1000+) and this may be a prohibitive factor for large studies. Need for batteries to avoid meter shut down during blackouts increases the cost.
- Case studies where magnetic flow meters have been used include Wyong- NSW Foody (2006a) and New Zealand (Heinrich 2006).

### *Actaris Flow Meters and Data Loggers*

Actaris flow meters were used by Sydney Water for their Sydney end-use metering programme from 1998 to 2004. Poor resolution from the flow meters and data loggers meant that small water use events such as water use from taps could not be identified (Foody 2006a).

Their high resolution meters have been used in the Gold Coast case study successfully (see case study box in Section 4).

### **Data loggers**

Data loggers can record and time stamp pulses from water meters. Consequently they can continue to measure water flow rates for as long as there is sufficient memory and battery capacity. They can receive inputs from either a single water meter or several water meters depending on the logger (e.g. some loggers have 4 or 8 input channels). The information recorded by data loggers can then be sent off via a number of methods: manual collection, wireless modems, dial up links, via a company's LAN (Cordell et al. 2003; Hauber-Davidson and Idris 2006).

The requirements for data loggers include:

- The ability to record flow rates down to 10 second or finer intervals (e.g. 1 second, however the optimum sampling frequency depends on the context and requires further research). This means that the data logger stores in its memory the number of flow meter pulses during a 10 second period.
- Sufficient memory capacity, which depends on sampling and download frequency.
- Practical time to download information from the data logger.

Data loggers that have a mobile phone chip installed can transmit the data to a computer connected to a phone line. It is important to sort out which flow meter suits the end-use measuring project before buying data loggers as not all data loggers and flow meters are capable of communicating (Heinrich 2006).

Data loggers can be configured to be non-intrusive to the householders, which is advantageous for observing behaviour without influencing that behaviour. Data loggers need appropriate software for downloading data, and staff training to analyse the readings. Data loggers can have problems communicating with water meters, and via the various data transfer options (Cordell, Robinson et al. 2003; Heinrich 2006).

### *Gemini Tiny Tag data loggers*

A Gemini Tiny Tag data logger has been used by Foody (2006a) to measure and collect water usage data in Wyong Shire on the Central Coast of NSW. It had a small memory capacity requiring daily downloads.

The Gemini Tiny Tag data loggers can record data down to 1 second and have been reliable and accurate in previous studies. The data loggers come with a Windows based software that allows programming and data collection (Gemini Data Loggers 2006).

Current models are battery operated and have a memory capacity for 16,000 readings.

Issues:

- Available models allow only manual data download.

#### *WaterGuard® Leak Detection and Flow Isolation Devices*

Watersave Inc. adjusted their automatic WaterGuard® leak detection and flow isolation device so it could be used as a smart meter. WaterGuard have been used by Sydney Water to put inside homes.

The WaterGuard device connects to the company's computer network by opening a secure port, or sends a signal via wireless modem. EP&T, Intermoco, Metering Dynamics etc provide similar services via web sites, email services or BMS (Hauber-Davidson and Idris 2006).

Benefits:

- WaterGuard can cut off water flow into a premises when it detects water leaks.
- Powered by mains power with a battery backup.
- Data can be transferred manually, via radio or mobile connection as the device is enabled to use Bluetooth technology.
- Google Analytics software is free from the company (Watersave Australia 2006).

Issues:

- Currently WaterGuard does not record more often than every 1 minute. Watersave Australia will change their software programme to record every 10 seconds if a company purchases a large amount of equipment (Marsh 2006).
- WaterGuard needs to be attached to pulse probe meters in order to receive data from the water meters.

#### *Meter-Master® Data Loggers*

The US Company F.S. Brainard and Company manufacture Meter-Master Data Loggers. These data loggers were designed to collect water flow data from US magnetic-driven water meters and analyse the data using Aquacraft's Trace Wizard® flow trace analysis software (Aquacraft 2006; F.S. Brainard and Company 2003).

The data loggers are expensive and difficult to obtain from Australian distributors so have rarely been used in Australia to date (Foody 2006a).



## Additional considerations

There are several additional considerations for using water meters and data loggers

- Security, which relates to whether or not meters are left out in the open and the risk of theft or damage.
- Exposure to weather (more expensive equipment may be required to cope with freezing conditions).
- Total capital, installation and operating costs over the life of the meter.
- Meters and data loggers can have built in batteries, be solar powered, have double battery packs for units that have special sleep mode which can last up to 3 months without recharge, or hooked up to permanent power supply. However, during mains power blackouts, data loggers also stop recording. It is best to have an independent power source (Hauber–Davidson and Idris 2006).

## Household inspection, interview, bucket and stopwatch

This method relies on a manual measurement on the part of the data collector. A person enters a residential dwelling and manually determines how much water an end-use activity consumes over a period of time by asking the resident to use each water using appliance normally (i.e. how far "on" do they usually have the shower during use), filling a bucket with water from a shower over a 1 minute period, measuring the volume of water. An interview would then be conducted to ask each resident about their water using behaviour.

This method can be useful in conjunction with more automated data collection from meters when commencing a study. This verifies that the data collected by the data loggers correlates with the amount of water used by the actual end-use device found in the home. Therefore, the amount of water collected and measured using the bucket and timer should be very similar to the data logger readings for the same length of time. This comparison has been used in some Australian studies, such as for the Water Corporation of WA in Perth (Cordell et al. 2003) These are described in further detail in Section 5.

In an ongoing study, the interview regarding behaviour can be supplemented with a log book that asks the resident to note their water using behaviour over the period of the study.

## Other methods of data collection

There are opportunities to link water metering with additional information to assist in discerning end-uses, for example:

- Signals from electricity meters could identify electrical consumption of water-using appliances to determine when and how much water these appliances are using.
- It is also possible to record discrete events (such as installing a switch on the toilet to register every time it is flushed) and use this information to later unpack simultaneous events that are found in Trace Wizard analysis.

## A2.2 METHOD OF DATA TRANSFER

Once collected, data must be transferred to a central location for analysis. This sub-section describes approaches to data transfer for collected metered data.

The transfer of data can be manual or automated, and can use a one-way or two-way communication with the data collector. Automated data transfer involves fixed and wireless options. Fixed options include telephone landlines, e.g. PSTN, ISDN, cable/ADSL. Wireless options include mobile technology (GSM); radio frequencies such as GPRS and Low Power Radio (LPR); local computer networks (LAN) and secured internet lines (Idris 2005; Owen and War 2006).

One-way communication entails communication from the water meter to the data logger and is referred to as Automatic Meter Reading (AMR). Two-way communication entails communication between the meter and the supplier and is known as Automatic Meter Management (AMM). An interval meter can be used with AMM technology, in which case the meter stores and transmits consumption data broken down into time intervals (e.g. half hour intervals) (Owen and War 2006).

A radio-based system to monitor the water meters remotely can be used as part of an AMR system. Low power radio communication devices send live water meter data to an on-site computer database. Information about flow rates and consumption can be viewed and exchanged with other users and corporate software packages. Reports can be compiled analysing leakage profiles, over-consumption issues and performance measured against targets (Scottish Water 2006).

The following are some benefits from Automatic Meter Reading services:

- Able to measure and track trends in usage
- Can identify possible leaks and waste minimisation opportunities
- Can benefit from early warning of low or high water flows
- Able to view data online 24 hours a day
- Able to access consumption data remotely (Scottish Water 2006).
- The layout of the site and ease of installation determine the type of data transmission options used. Figure 7 shows the various options for data transmission.

Equipment required to transfer data from the water meter to the database include:

1. Modem for internet use
2. Wireless or mobile connection
3. Laptop for manual download
4. Telephone lines for internet use

Figure 7: Smart Water Meters Data Transfer (Hauber -Davidson and Idris 2006)

### Available Data Transfer Options for Smart Water Meters

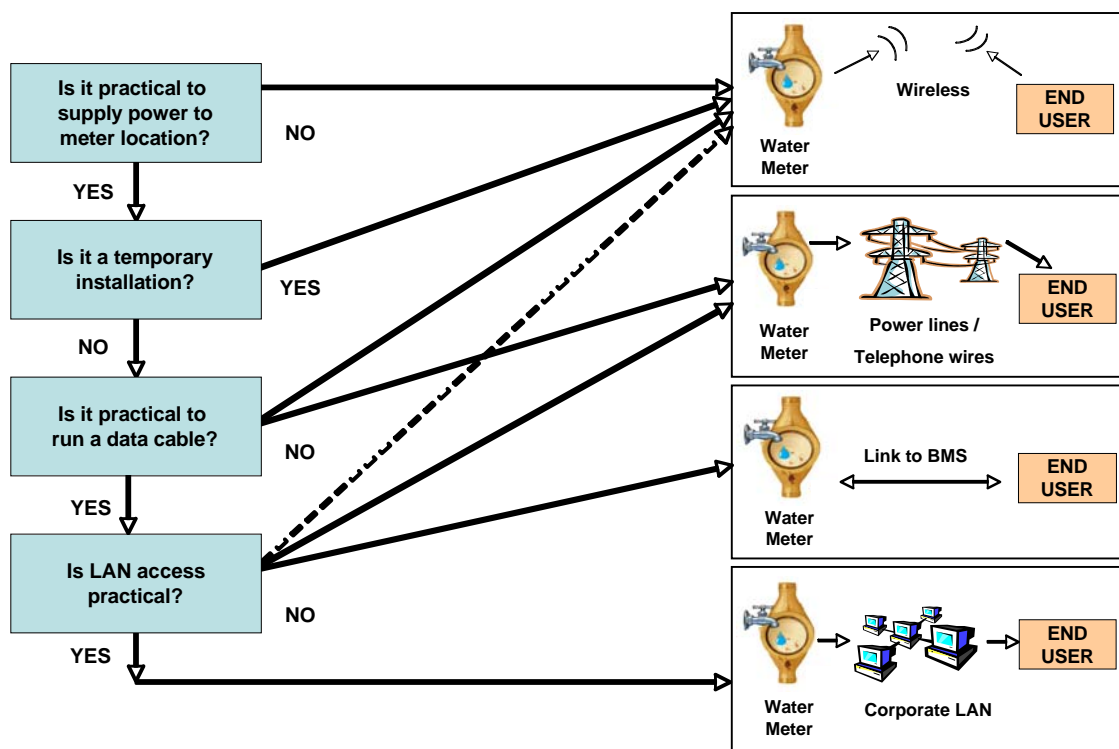

#### Manual data transfer

A laptop is manually connected to the data logger and data is downloaded for analysis back in the office. This procedure requires one person to physically visit the location of each logger. It can be time consuming, labour intensive and costly if collecting data from a large number of dwellings or across a large area. It is also intrusive, as the collector has to enter the residential property in order to download the data. Manual data collection is more beneficial if the data collection sites are few and close together.

#### Data transfer via mobile and radio frequencies

The data logger sends data to a server via a mobile or radio wireless modem with a micro-controller interface. The modem can be activated using General Packet Radio Service (GPRS), Evolution Data Optimised (1xEVDO) or the Global System for Mobile (GSM) technology or its successor G3 (Idris 2005).

GSM is the standard mobile link used currently. GPRS is the second generation of mobile technology; 1xEVDO is the current Telstra wireless broadband platform, which will be phased out with the introduction of the third generation mobile telephony platform (G3).

Wireless technology operates over longer distances compared to Bluetooth technology. It is possible to drive past wireless smart meters and collect data without physically visiting the site to perform manual download of the data. Wireless connection can be more expensive if the project is thinking in terms of smart meters alone, but wireless technology can have a number of other uses that provide benefits. Labour costs are reduced by not collecting data on-site. Instead, data is sent directly to computers, or other data storages, via mobile and radio frequencies (Hauber-Davidson, 2006).

## A2.3 METHOD OF DATA ANALYSIS

Data analysis refers to how the data is analysed to identify end-uses.

Data can be directly accessed by the customer and water utility 24 hours a day if desired, via an intranet system or a secured internet line (Scottish Water 2006). A number of website providers can collect the raw data from water meters, convert the information into litres per minute or hour, and provide access to a secured website for a monthly or one-off fee. The water data that is stored in the web provider's databases can be up-loaded, displayed in graphs and tables or different file formats (Neptune Technology Group 2003). Google Analytics (used by Water Save Australia) is another approach for graphing raw-data in a web-based environment. Examination of raw data as simple averages may be sufficient to determine leaks, but not to discern end-uses, which requires additional algorithms for interpretation of the data.

A number of different software programs have developed such algorithms to analyse water use data, such as flow trace analysis (e.g. Trace Wizard, WRC – Identiflow).

Alternatively, if data is recorded together with specific event counters (e.g. when a toilet is flushed, when a shower is operated) a neural network approach could be used to 'teach' the computer what a characteristic trace associated with, for example, a toilet flush looked like.

### Software used to analyse and access data

#### *Trace Wizard® Flow Trace Analysis.*

Trace Wizard software was developed by Aquacraft Inc, a Colorado company based in the USA, to analyse flow traces collected by Meter Master data loggers of Brainard and Company. Trace Wizard was designed to read American water meter specifications, which tend to be magnetic-driven. Therefore, the default parameters need to be reset to read Australian water meters, data loggers, fixtures and appliances. Aquacraft are able to help with these readjustments (Foody 2006a; Mayer 2006). Trace Wizard tends to be the most commonly used data analysis software in Australia.

Trace Wizard can be reset to identify parameters for each corresponding end-use type. For hard to identify events, an analyst trained in Trace Wizard software can reset the programme to identify the correct end-use using the graphical user interface. The analysis can take time and effort but the set-up time and amount of hardware needed is reduced. Residence details are generally not needed due to the methodology of Trace Wizard, which helps to reduce bias in the data (Heinrich 2006a).

Trace Wizard records the volume, duration, peak and modal flow rate of each water-using event over the specified time period. The flow trace produces a spike which accurately identifies how much water is consumed at a particular time. Figure 8 of this Appendix shows the different peaks produce by four different end-uses (shower, toilet flush, clothes washer and hand taps). Each end-use is tested and timed at the beginning of a study and aligned with the Trace Wizard spike of that end-use to ensure that the data loggers are recording and the parameters are defined correctly (Heinrich 2006a).

**Figure 8: Example output from Trace Wizard**

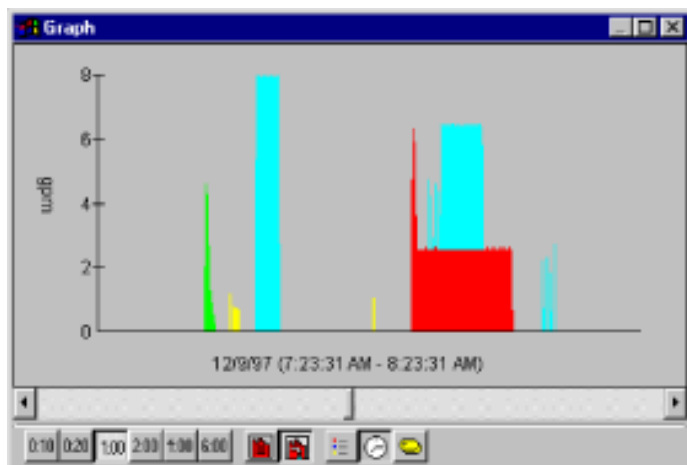

The blue peaks in Figure 8 show the volume of water (galleons per minute) used by the clothes washer. The clothes washer shown here has two primary cycles (wash and rinse) and a number of extractor/spin cycles before and after the rinse cycle. The red peak is a shower running simultaneously with the clothes washer. A toilet flush is green and hand taps are in yellow (Aquacraft website accessed 7 Aug 2006).

Trace Wizard uses Microsoft Access so the data collected from the data logger needs to be converted in order for Trace Wizard to analyse the data.

Benefits:

- Trace Wizard accurately measures particular water events for volume and time.
- The software allows very little intrusion into people's homes to measure their water consumption in detail.
- It can take measurements 24 hours a day, down to 1 second intervals if required. 5-10 second intervals have been found to provide the best level of detail without having too much or too little data and is easy to adjust if want to change the time intervals.
- Once the analysts are trained to use Trace Wizard correctly, it can be easy to use with a month's data being analysed in a couple of hours. (Heinrich 2006a; Mayer 2006).

Issues:

- It is difficult to clearly distinguish which trace flow signature is for what particular end-use when large and small water events occur either simultaneously or overlap, e.g. when a tap is turned on while a shower is running or toilet is flushed.
- Flow trace analysis has not been used on low pressure water systems. Problems could arise from adjusting the water system to reduce undesirable effects such as reduced shower pressure, which in turn may affect the ability of the equipment to measure water use accurately. According to Peter Mayer of Aquacraft, Trace Wizard would probably show lower and more similar flow traces, which may reduce its ability to identify all the water events.

These problems can influence those analysing the data to:

- underestimate the volume of water attributed with hand washing (especially following toilet use);

- underestimate the number of toilet flushing events; and
- overestimate the volume of water associated with toilet flushing (Foody 2006a).

Trace Wizard software has been used in the following studies:

- 1998-2001 Perth domestic water use study (Loh and Coghlan 2003) – used Meter-Master data loggers and Trace Wizard software. The report didn't detail methodology of data collection and analysis. Less detailed results compared with USA Trace Wizard studies by Mayer and DeOreo (Foody 2006a).
- 1998-2004 Sydney end-use metering programme (Sydney Water Corporation 2004) – used Actaris flow meters and data loggers and Trace Wizard software. Flow meters and data loggers couldn't identify small water events. Trace Wizard couldn't allocate more than 30% water use events (Foody 2006a).
- 2004 Yarra Valley Water end-use metering programme – used local meters and data loggers. Yarra Valley Water sent data to Aquacraft to analyse using Trace Wizard and found the results were reliable with very few flow traces unallocated (Foody 2006a).
- 2005 Central Coast domestic potable water DM (Foody 2006) – study conducted in Wyong and partly in Gosford City. A Rosemount 8700 Series Magnetic Flowmeter System meter was used (changed the existing mechanical meter as it couldn't take a pulse counting device), with a Gemini Tiny Tag data logger and Trace Wizard software. The software worked well but was limited by small data logger memory (Foody 2006a).

#### *Web-based Analysis*

A number of companies use their website to store and analyse data for the customer, such as Watersave Australia, WRc, USUS. A user name and password are supplied to the customer, who can pay a monthly or yearly fee to access the water data. The data can be accessed by the customer 24 hours a day, seven days a week, facilitating feedback to customers.

#### *Identiflow® Software*

Identiflow, developed by Water Research Centre (WRc UK) and shown in Figure 9, identifies water end-uses through signature analysis.

Issues:

- WRc seem not to have set up Identiflow as a commercial product but as more of an in-house product for their research work. WRc have suggested the preferred method of data analysis is to send data sets to them for analysis (WRc 2006).

Figure 9: Identiflow Screen

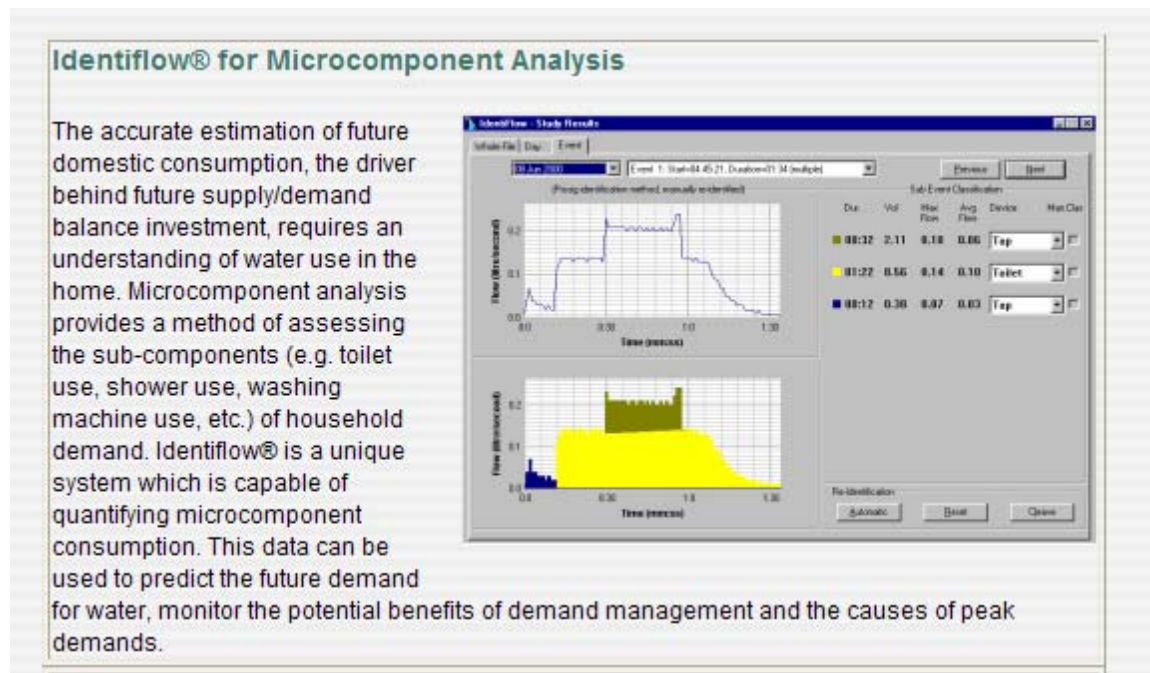

### Google Analytics

Google analytics is a free mini analytical software package from Google that is a spreadsheet and a basic graphing tool. It provides analysis of trends, identifies problem areas, compares seasonal data, and provides the information in user-friendly reports and graphs (Google 2006). Google analytics is used by Watersave Australia.

For further details on research using this equipment see Wong and Branz case studies (Foody 2006, Heinrich 2006).

**Note: references cited in the appendices are included in the References section p29**

## APPENDIX 3 END-USE MEASUREMENT TECHNOLOGY MANUFACTURERS

Company name	Technology	Further information
Aquacraft, USA	Trace Wizard analysis software	<a href="http://www.aquacraft.com/">www.aquacraft.com/</a>
Actaris, Global	Meters and AMR	<a href="http://www.actaris.com/">http://www.actaris.com/</a>
Brainards, USA	Meters	<a href="http://www.meter-master.com/">http://www.meter-master.com/</a>
Bayard Group (Ampy+Email metering)	Combined water/ electricity smart meters	<a href="http://www.ampyemail.com.au/">http://www.ampyemail.com.au/</a>
Elster, Australia	Pulse meters	<a href="http://www.elstermetering.com/">www.elstermetering.com/</a>
Gemini Data Loggers Ltd, UK	Data loggers	<a href="http://www.gemindataloggers.com/">www.gemindataloggers.com/</a>
Global Water, USA	Smart meters, loggers, web analysis	<a href="http://www.globalw.com/">www.globalw.com/</a>
Google Analytics	Analysis	<a href="http://www.google.com/analytics/home/">www.google.com/analytics/home/</a>
Great Plain Industries Inc, USA	Turbine meters	<a href="http://greatplains.thomaswebs.net/index.html">http://greatplains.thomaswebs.net/index.html</a>
Landis and Gyr, Germany	Ultrasonic meters	<a href="http://www.landisgyr.com/">www.landisgyr.com/</a>
ManuFlo, Australia	Meters	<a href="http://www.manuflo.com/">www.manuflo.com/</a>
Monatec, Australia	Data loggers	<a href="http://www.monatec.com/">http://www.monatec.com/</a> or <a href="http://www.aegis.net.au/">http://www.aegis.net.au/</a>
Neptune	Meters	<a href="http://www.neptunetg.com/">www.neptunetg.com/</a>
Rosemount Inc, USA	Meters	<a href="http://www.rosemount.com/">www.rosemount.com/</a>
USUS, Australia	Data transfer and web analysis	<a href="http://www.usus.com.au/">www.usus.com.au/</a>
Watersave Australia Pty Ltd	Meter with leak-shutoff, smart transfer and web-analysis	<a href="http://www.watersave.com.au/WaterGuard/default.asp">www.watersave.com.au/WaterGuard/default.asp</a>
Wellspring Wireless	Metering for individual appliances	<a href="http://www.wellspringacquisition.com/">www.wellspringacquisition.com/</a>
WrC, UK	Analysis software	<a href="http://www.wrcplc.co.uk/default.aspx?item=254">www.wrcplc.co.uk/default.aspx?item=254</a>