



---

## User Manual

# ME5-T RESETABLE TOTALISER LCD Indicator

---

***ManuFlo***<sup>®</sup>*™* Flow Measurement Products  
A Division of Manu Electronics Pty Ltd  
41 Carter Road,  
Brookvale NSW 2100 Australia

Phone: +61 2 9938-1425 or +61 2 9905-4324  
Fax: +61 2 9938-5852  
E-mail: [sales@manuelectronics.com.au](mailto:sales@manuelectronics.com.au)  
Website: <http://www.manuelectronics.com.au/>

(c) 2005 Manu Electronics Pty Ltd  
0512/1

## Table of Contents

|             |                                                                  |          |
|-------------|------------------------------------------------------------------|----------|
| <b>1.0</b>  | <b>INTRODUCTION</b> .....                                        | <b>1</b> |
| 1.1         | ORDER CODE.....                                                  | 1        |
| <b>2.0</b>  | <b>TECHNICAL/ELECTRICAL SPECIFICATION</b> .....                  | <b>2</b> |
| 2.1         | SAFETY/WARNINGS .....                                            | 2        |
| <b>3.0</b>  | <b>EXTERNAL VIEW</b> .....                                       | <b>3</b> |
| <b>4.0</b>  | <b>LCD DORMANCY (BATTERY POWERED VERSION ONLY)</b> .....         | <b>4</b> |
| <b>5.0</b>  | <b>MOUNTING</b> .....                                            | <b>4</b> |
| <b>6.0</b>  | <b>CONNECTING POWER SUPPLY</b> .....                             | <b>4</b> |
| 6.1         | CONNECTING EXTERNAL AC POWER SUPPLY .....                        | 5        |
| 6.2         | CONNECTING EXTERNAL DC POWER SUPPLY (5 - 25 VDC) .....           | 5        |
| 6.3         | REPLACING INTERNAL BATTERY (BATTERY POWERED VERSIONS ONLY) ..... | 5        |
| <b>7.0</b>  | <b>CONNECTING INPUTS</b> .....                                   | <b>6</b> |
| 7.1         | COIL .....                                                       | 6        |
| 7.2         | REED SWITCH, OR NPN OPEN COLLECTOR .....                         | 6        |
| 7.3         | PULSE/NAMUR INPUT .....                                          | 6        |
| <b>8.0</b>  | <b>CONNECTING OUTPUT</b> .....                                   | <b>7</b> |
| <b>9.0</b>  | <b>ADJUSTING CALIBRATION</b> .....                               | <b>7</b> |
| <b>10.0</b> | <b>TROUBLESHOOTING</b> .....                                     | <b>9</b> |

## List of Tables

|          |                                                        |   |
|----------|--------------------------------------------------------|---|
| Table 1. | ME5-T Totaliser Indicator Product Ordering Codes ..... | 1 |
| Table 2. | Functions of the Internal Calibration Buttons. ....    | 8 |

## List of Figures

|           |                                                                       |   |
|-----------|-----------------------------------------------------------------------|---|
| Figure 1. | External view of ME5-T Totaliser Indicator .....                      | 3 |
| Figure 2. | ME5-T Internal PCB - Connectors and Calibration Buttons. ....         | 4 |
| Figure 3. | Connecting External AC Power via Connector X1. ....                   | 5 |
| Figure 4. | Connecting External DC Power via Connector X2.....                    | 5 |
| Figure 5. | Connection of Coil, Reed or Pulse/NAMUR Inputs via Connector X2. .... | 6 |
| Figure 6. | Connection of Pulse Output via Connector X2.....                      | 7 |
| Figure 7. | Adjusting the Calibration Value using the Calibration Buttons. ....   | 8 |

## 1.0 INTRODUCTION

The ME5-T Totaliser is designed to operate with a wide range of pulse/signal output or coil/reed output flowmeters, providing a resetable Total display.

The ME5-T Totaliser has a 5 digit LCD display, and is supplied with the LCD display programmed to show the Total in one of a number of different indicated values.

The Total is reset by simply pushing the lid button once. Optionally, the Total can be reset via an internal pushbutton, in which case the lid button simply wakes the display if it has gone into sleep mode.

Power is via either an internal Lithium battery with a life of up to 10 years, or via external 5-25 VDC supply or 240 vac supply (an internal transformer is fitted).

The ME5-T will accept flowmeter input pulses from 0.2 to 2,000 Hz frequency range.

The ME5-T is housed in a compact IP65 Polycarbonate enclosure with moulded mounts, which allows the ME5-T to be used in a wide range of field applications.

The ME5-T provides a non-isolated pulse output, for uses such as a data logger or a secondary counter PLC device.

All application parameters are pre-programmed, including display unit preferences and the flowmeter K-factor, according to the flowmeter chosen and the desired display setup.

Scaling can be recalibrated if necessary, using internal key pads.

### 1.1 Order Code

Table 1 below shows how the product order code for the ME5-T Totaliser Indicator is made up from the available combinations of power sources and display choices.

| <b><u>ME5-T TOTALISER LCD Indicator – Product Order Codes</u></b>                                                      |   |          |                         |
|------------------------------------------------------------------------------------------------------------------------|---|----------|-------------------------|
| <b>ME5 – T (-IR) – power – No. of decimal places – units</b>                                                           |   |          |                         |
| ↑                                                                                                                      | ↑ | ↑        | ↑                       |
| add for Internal Reset, else omit.                                                                                     |   |          |                         |
| Battery (without pulse output) = <b>B</b>                                                                              |   | <b>0</b> | <b>ML</b> = MilliLitres |
| Battery (with pulse output) = <b>BP</b>                                                                                |   | <b>1</b> | <b>L</b> = Litres       |
| external DC power = <b>D</b>                                                                                           |   | <b>2</b> | <b>KL</b> = KiloLitres  |
| external AC power = <b>A</b>                                                                                           |   |          | <b>M</b> = Megalitres   |
| <i>e.g. "ME5-T-B-1-L" is ME5-T Totaliser, internal battery powered, with display to 1 decimal place showing Litres</i> |   |          |                         |

**Table 1. ME5-T Totaliser Indicator Product Ordering Codes**

*Note: The combinations available depend on the characteristics of the Flowmeter used.*

## 2.0 Technical/Electrical Specification

### Display

- **Total** LCD, 10mm high digits.
  - Resetable. 5 digits up to 2 decimal places, in Millilitres, Litres, Kilolitres, Megalitres

### Power Options

- Battery
  - 3.6v Lithium battery (5 -10yrs life). (Use of battery is only suitable in conjunction with Reed or Coil flowmeters).
  - automatic sleep mode to preserve battery power (only if a battery powered unit).
  - consumption:
    - 80µA during 'on' state while counting,
    - 10µA in dormant state.
- External power DC
- External power AC
  - +5 to 25 VDC (supplies same voltage level to external flowmeter)
  - 240 vac (supplies 10VDC to flowmeter )

### Output

- Pulse output
  - Scalable via program.
  - Non-isolated 5-25 VDC. Maximum 100Hz, 100mA.
  - 5ms minimum pulse width.

### Enclosure

- Dimensions (mm)
  - 120 Width, 95 Height, 60 Depth
- Rating IP66
  - Waterproof Polycarbonate enclosure with protective cover and external lugs for mounting.
- Access
  - removable stainless steel screws to access internal programming and wire-up.
- Electrical connection
  - IP67 cable gland entry (1 entry if Battery powered, 2 if externally powered),
  - screw terminal connections.

Note: due to continuous product improvement, specifications are subject to change without notice.

## 2.1 Safety/Warnings

- The ME5-T is not certified for intrinsically safe applications, and is not recommended for use in hazardous areas.
- Ensure that gland entries to the ME5-T are properly sealed, as any water ingress may damage the ME5-T and will void the warranty.
- Do not attempt to recharge, disassemble, heat above 100 degrees C or incinerate the Lithium battery, or expose its contents to water.
- Prolonged direct exposure to sunlight (i.e. continuous exposure for months) may cause the Liquid Crystal Display (LCD) to fade. Use the cover to protect the LCD whenever the display does not need to be observed.

### 3.0 External view

The ME5-T is in a sealed polycarbonate enclosure with (as shown in Figure 1 below):

- a. cover, to protect the LCD.
- b. 4 removable Stainless Steel screws that secure the lid;
- c. the lid;
- d. Liquid Crystal Display (LCD) on the front panel;
- e. two screw lugs (one each side) for mounting;
- f. the units of the display;
- g. cable entry at the bottom:
  - o there is only one cable entry if the unit is battery powered, otherwise
  - o there are two cable entries if the unit is externally powered.
- h. button: to reset the Total; or to wake up the display (if a battery powered or Internal Reset version).

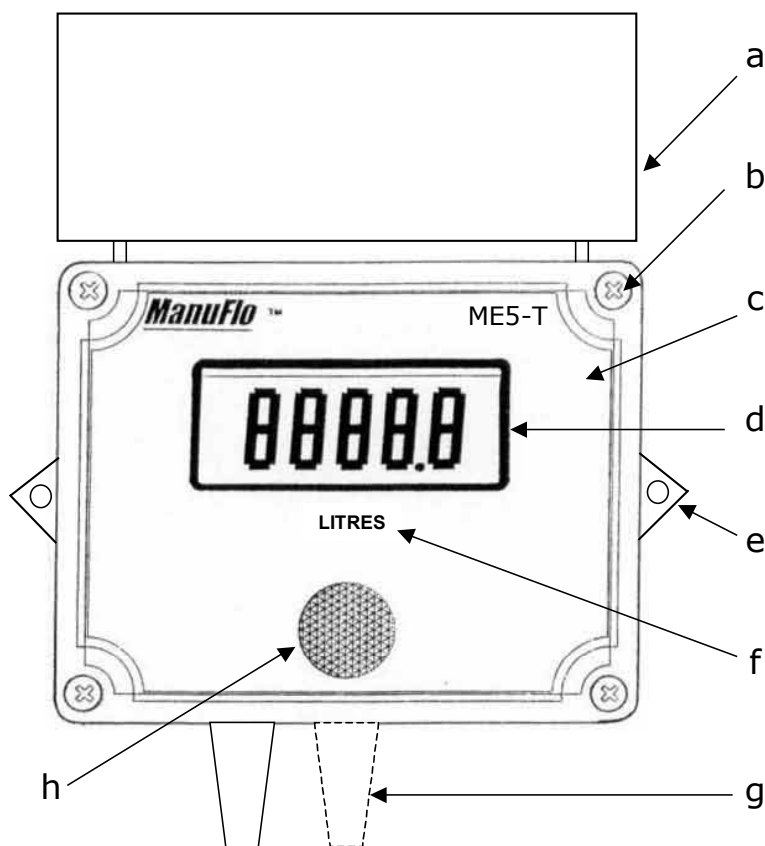

**Figure 1. External view of ME5-T Totaliser Indicator**

The single-line LCD is used to display the Total, using 5 digits (the number of decimal places is configurable at the time of ordering, using the product code as described in Table 1 on page 1).

#### **Resetting the Total**

The Total is reset when the button on the lid (see Figure 1-h above) is pressed once.

Optionally (-IR version, where lid button is marked "WAKE"), the total is reset via an internal pushbutton (see Figure 2 on page 4), and the lid button simply wakes the display if it has gone into sleep mode.

#### 4.0 LCD Dormancy (Battery powered version only)

If the ME5-T is the battery powered version then, to conserve battery power, the ME5-T will become dormant, and the LCD will go blank, after a period of no activity (i.e. no pulses are received).

The ME5-T is awakened from its dormant state, and the LCD display comes back on, if:

- the ME5-T receives more pulses from an attached flowmeter; or
- the button on the lid (Figure 1-h on page 3) is pressed. Note: any total will not be reset by the button press that wakes up the display. Once the display is awake and displaying a value, then any subsequent button press will reset the displayed total. (Optionally, in the -IR version, the total is reset via an internal pushbutton as shown in Figure 2 below, and the lid button simply wakes the display if it has gone into sleep mode).

If the LCD does not waken from its dormant state, then the internal battery may need to be replaced.

Note: if the ME5-T is not a battery powered version, then the ME5-T does not become dormant and the LCD always shows a value.

#### 5.0 Mounting

The ME5-T has two external lugs for mounting (see Figure 1-e on page 3). Do not overtighten the mounting screws when using these lugs (Note: mounting screws are not supplied with the ME5-T).

#### 6.0 Connecting Power Supply

Power supply connections are made by running the power cable through the cable entries of the enclosure, to the screw terminal connectors located on the Printed Circuit Board (PCB) inside the ME5-T (see Figure 2 below). The PCB is accessible by removing the four Stainless Steel screws and the front panel from the enclosure.

To make a proper connection to the Connectors, insert each cable's bare wire end into the screw terminal, and use a screwdriver to screw down the terminal until tight. Do not screw down on the wire's insulation, as this will not make a proper electrical contact.

Note: in the event of total loss or disconnection of battery power, the ME5-T will not lose any calibration data because the internal memory is EEPROM which will retain data even if power is disconnected. However the Total will be lost.

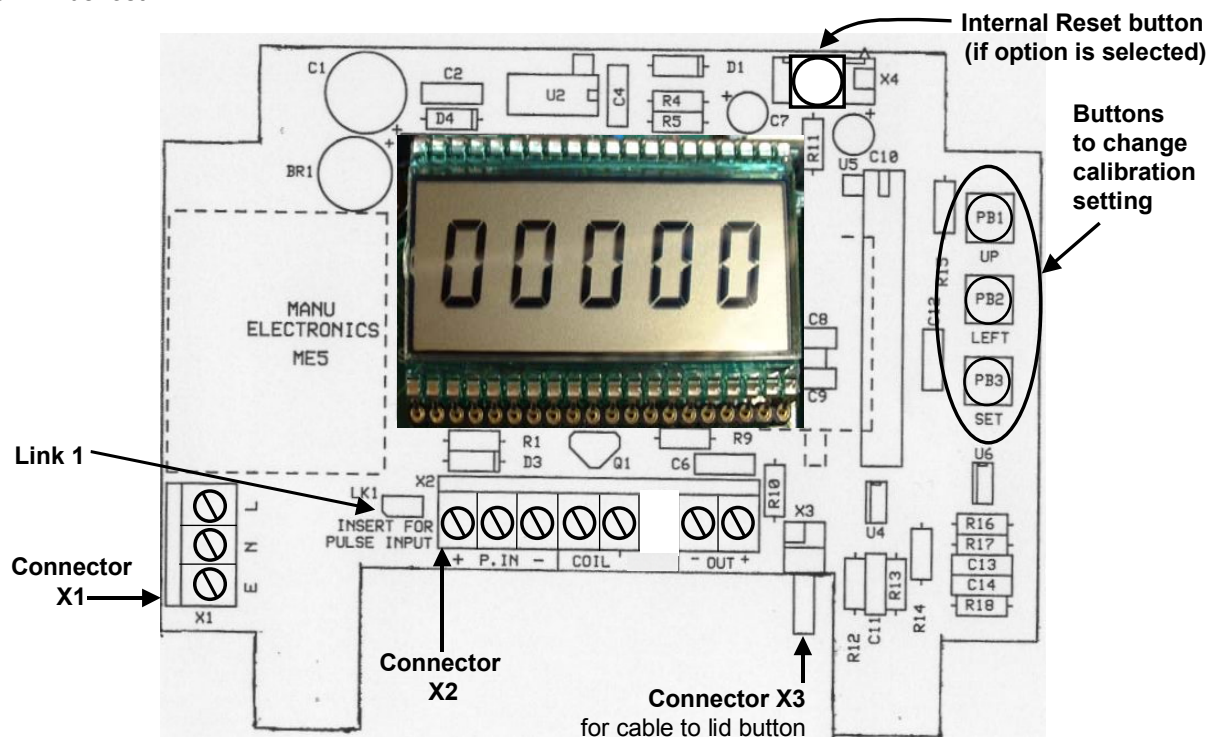

Figure 2. ME5-T Internal PCB - Connectors and Calibration Buttons.

## 6.1 Connecting External AC Power Supply

**DANGER**

To avoid the danger of electrocution, ensure that the wiring bringing external 240 vac mains is disconnected from the mains supply before connecting the wiring to the ME5-T.

If the ME5-T is an AC power version (ME5-T-A-), then the ME5-T has a 240 vac transformer fitted internally, and a power cord is supplied. The external mains power cables (Active, Neutral and Earth) are connected through the second cable entry to the PCB connector X1, as shown in Figure 3 below.

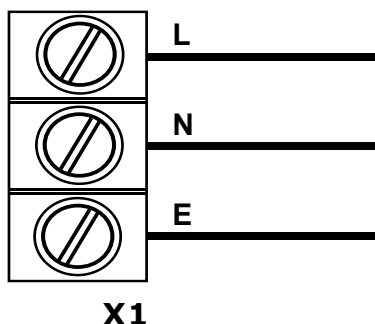

Figure 3. Connecting External AC Power via Connector X1.

## 6.2 Connecting External DC Power Supply (5 - 25 VDC)

If the ME5-T is a version requiring External DC Power (ME5-T-D-), then connect the external power supply through the second cable entry to the PCB connector X2, as shown in Figure 4 below.

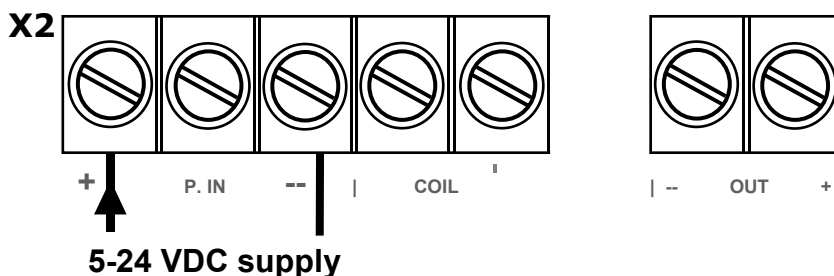

Figure 4. Connecting External DC Power via Connector X2.

## 6.3 Replacing Internal Battery (Battery Powered versions only)

If the ME5-T is a battery powered version (ME5-T-B-), then it will be supplied with an internal battery already fitted. Where fitted, the internal battery:

- is soldered to the underside of the interior circuit board;
- is a 3.6 v AA Lithium battery

Battery life is normally at least 5 years from the date of battery installation, and may be up to 10 years depending on usage.

Where the ME5-T is battery powered, and battery power becomes low:

- the LCD will become dim or go blank;
- the battery must be replaced as soon as possible, by:
  - returning the ME5-T to Manu Electronics (see cover page for address); or
  - removing the front panel and internal Motherboard, and replacing the battery which is attached to the Motherboard (any commercially available 3.6 v AA Lithium battery is suitable).

**Ensure that the replacement battery is positioned for correct polarity.**

Note: Carefully dispose of the old Lithium battery.

**CAUTION**  
Do not attempt to recharge, disassemble, heat above 100 C or incinerate the Lithium battery, or expose its contents to water.

## 7.0 Connecting Inputs

Note that if the ME5-T is a battery powered version, then only reed switch and coil inputs from a flowmeter are suitable because they are low current consumption devices.

### 7.1 Coil

The ME5-T will accept a coil input from a flowmeter, through the cable entry to the internal PCB Connector X2 as shown in Figure 5-a below. Note the connection of the shielded cable.

### 7.2 Reed Switch, or NPN Open Collector

The ME5-T will accept a Reed Switch input, or an NPN Open Collector input, from a flowmeter through the cable entry to the internal PCB Connector X2 as shown in Figure 5-b below.

### 7.3 Pulse/NAMUR input

The ME5-T will accept a Pulse/NAMUR input from a flowmeter, through the cable entry to the internal PCB Connector X2 as shown in Figure 5-c below. **Note:** Link 1 (see Figure 2) is inserted for a pulse/NAMUR input.

Note: A NAMUR sensor requires power, so connect either:

- a 5-24VDC supply to internal PCB Connector X2, as shown in **Figure 5** below; or
- an external AC supply (to Connector X1, shown in Figure 3 on page 5) . This will then provide at pin 1 of Connector X2 an unregulated 10VDC for an 18mA load.

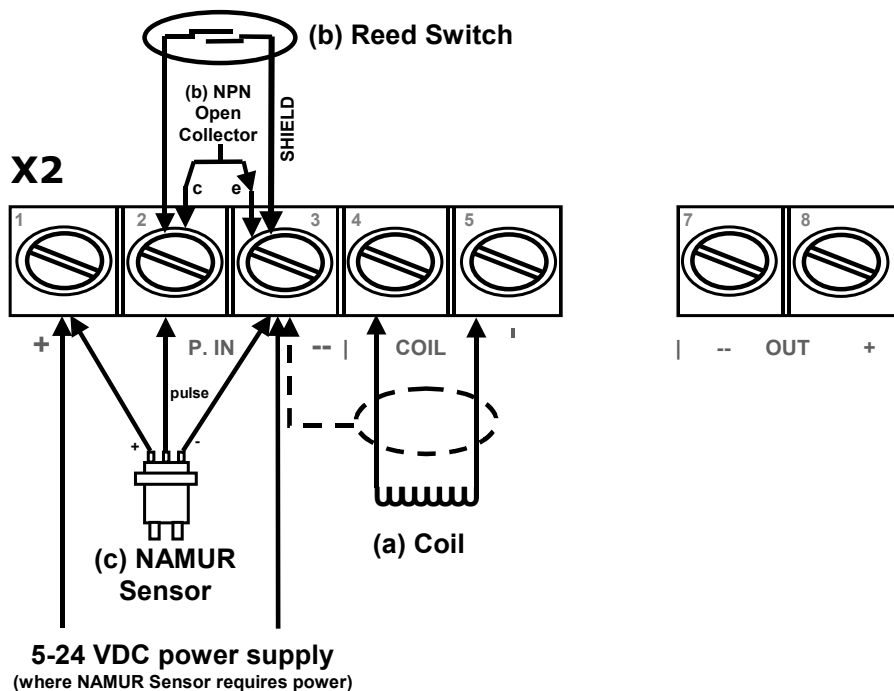

Figure 5. Connection of Coil, Reed or Pulse/NAMUR Inputs via Connector X2.

## 8.0 Connecting Output

Connection to the Pulse Output is via cable entry to the internal PCB Connector X2 as shown in Figure 6 below. The output is: NPN sinking pulse, 100Hz maximum, 100mA, 30V.

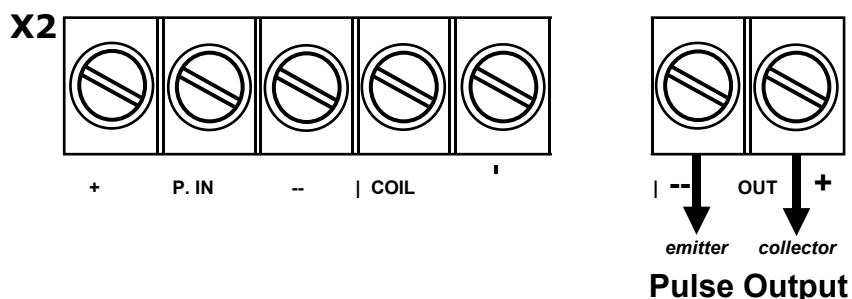

Figure 6. Connection of Pulse Output via Connector X2

## 9.0 Adjusting Calibration

The Calibration Value is a scaling factor held in the ME5-T's memory that takes into account:

- the K Factor (the number of pulses output by a flowmeter per volume of liquid delivered). The K Factor depends on the flowmeter being used with the ME5-T; and
- the units required for the Totaliser display; and
- the number of decimal places used in the LCD.

Manu Electronics will supply the ME5-T already configured for your needs, taking into account the flowmeter used with the ME5-T.

The user can verify on-site that the displayed Total is correct, by collecting a volume of liquid in a known volumetric container.

If required, the Calibration Value can be adjusted by the user to fine tune the displayed Total:



- Increasing the Calibration Value will decrease the Total displayed on the LCD.
- Decreasing the Calibration Value will increase the Total displayed on the LCD.

Example: If the Calibration Value is '2000', and the Total displayed is 1% higher than actual, then

to lower the displayed Total by 1%, the Calibration Value must be increased by 1% (i.e increased by 1% x 2000 = 20) to a new value of '2020'.

The user can adjust the Calibration Value of the ME5-T by:

- firstly removing the lid of the ME5-T to access the Calibration Buttons on the internal PCB (see Figure 2 on page 4); then
- using the Calibration Buttons to change the Calibration Value (as described on the next page by Table 2 and Figure 7).

| Calibration Button                                                                | Function                                                                                                                                                                                                                                                                                                                                                                                                                                                                                                                                                  |
|-----------------------------------------------------------------------------------|-----------------------------------------------------------------------------------------------------------------------------------------------------------------------------------------------------------------------------------------------------------------------------------------------------------------------------------------------------------------------------------------------------------------------------------------------------------------------------------------------------------------------------------------------------------|
|  | <p>LEFT:</p> <p>Selects the digit to be changed in the currently displayed calibration value:</p> <ul style="list-style-type: none"> <li>On first press, causes the right most digit of the calibration value to blink.</li> <li>Thereafter, moves focus to the digit to the left and causes that digit to blink.</li> <li>Cycles through the digits i.e. after the left-most digit, moves back to the right-most digit of the calibration value.</li> </ul>                                                                                              |
|  | <p>UP:</p> <ul style="list-style-type: none"> <li>increases the value of the selected digit (the digit that is blinking).</li> <li>Cycles through the values 0 -&gt; 9 -&gt; 0 -&gt; 9 etc.</li> </ul>                                                                                                                                                                                                                                                                                                                                                    |
|  | <p>SET:</p> <ul style="list-style-type: none"> <li>If the LCD is in Normal Mode displaying the Total: pressing the SET button changes the LCD to Calibration Mode.</li> <li>If the LCD is in Calibration Mode and there is a digit blinking: pressing the SET button locks in the value after a calibration setting has been modified and there will no longer be a digit blinking.</li> <li>If the LCD is in Calibration Mode and there is NOT a digit blinking: pressing the SET button returns the LCD to Normal Mode to display the Total.</li> </ul> |

**Table 2. Functions of the Internal Calibration Buttons.**

The Calibration Buttons 'UP', 'LEFT' and 'SET' are on the internal PCB board (see Figure 2, page 4).

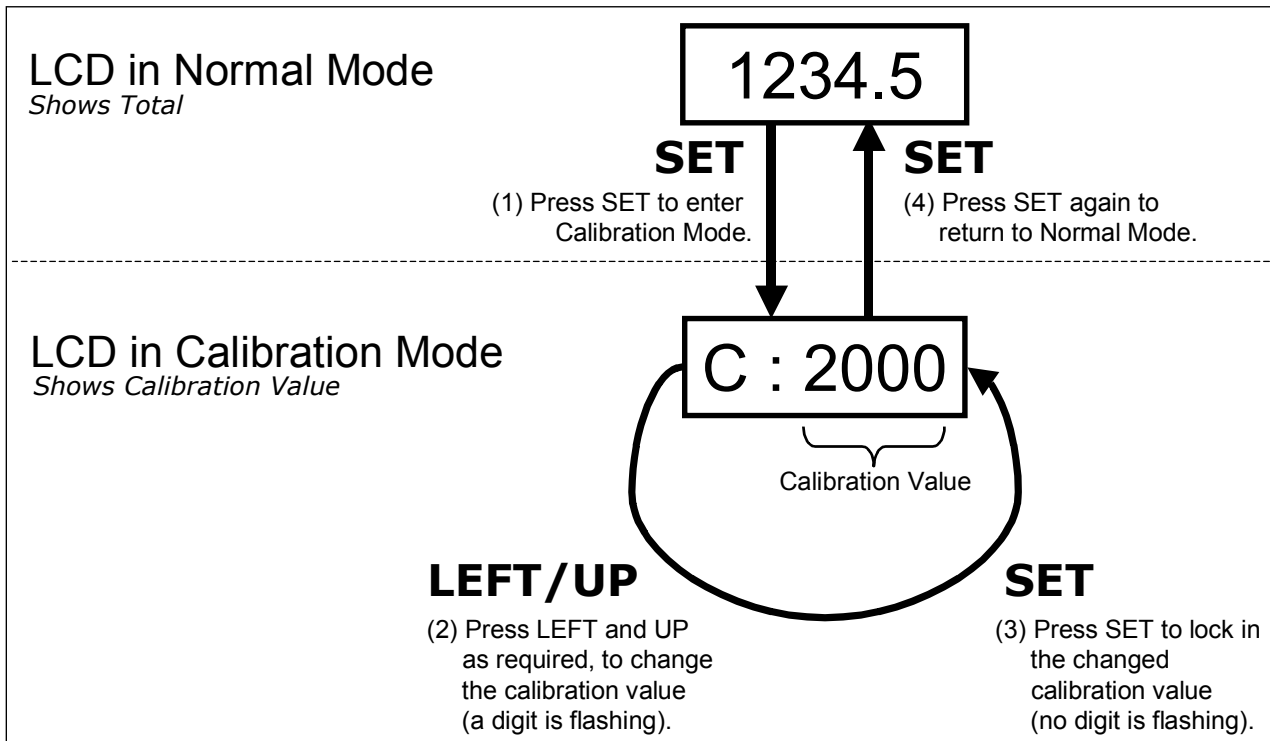

**Figure 7. Adjusting the Calibration Value using the Calibration Buttons.**

The Calibration Buttons 'UP', 'LEFT' and 'SET' are on the internal PCB board (see Figure 2, page 4).

## 10.0 TROUBLESHOOTING

| <u>Symptom</u>                                                       | <u>Solution</u>                                                                                                                                                                                                                                                                                                                                                                                                                                                                                                                              |
|----------------------------------------------------------------------|----------------------------------------------------------------------------------------------------------------------------------------------------------------------------------------------------------------------------------------------------------------------------------------------------------------------------------------------------------------------------------------------------------------------------------------------------------------------------------------------------------------------------------------------|
| ME5-T does not show any change in Total.                             | <ul style="list-style-type: none"> <li>• Check that the attached flowmeter is properly wired to the correct ME5-T input terminals for the type of flowmeter, and that the wiring from the flowmeter is not broken.</li> </ul>                                                                                                                                                                                                                                                                                                                |
| When on external power, the ME5-T does not show any change in Total. | <ul style="list-style-type: none"> <li>• Check that external power is not under 5V.</li> </ul>                                                                                                                                                                                                                                                                                                                                                                                                                                               |
| When on battery power, LCD is blank.                                 | <ul style="list-style-type: none"> <li>• ME5-T may be in dormant mode because it is not receiving input pulses from its attached flowmeter. Either: <ul style="list-style-type: none"> <li>○ press the button on the lid (Figure 1-h on page 3), or</li> <li>○ generate a signal to the ME5-T to check that the LCD can be re-awakened.</li> </ul> </li> <li>• If applying input pulses does not re-awaken the LCD, check if battery voltage is less than 3.6 V. If so, replace the internal battery (see section 6.3 on page 5).</li> </ul> |
| When on external power, LCD is faint.                                | <ul style="list-style-type: none"> <li>• Check that external power is not under 5V.</li> </ul>                                                                                                                                                                                                                                                                                                                                                                                                                                               |
| LCD is faint or discoloured.                                         | <ul style="list-style-type: none"> <li>• If there has been prolonged direct exposure to sunlight, then return the ME5-T to manu Electronics for servicing.</li> <li>• If there has been water ingress through the glands and the PCB is corroded, then the unit may not be repairable.</li> </ul>                                                                                                                                                                                                                                            |
| ME5-T counts when there is no flow.                                  | <ul style="list-style-type: none"> <li>• If the ME5-T is being used with a ManuFlo RPFS-L (Coil) flowmeter, interference from a 50Hz AC power field nearby may be causing false counts. Move the flowmeter away from the 50Hz field, or move the source of the field if practical.</li> <li>• For NAMUR sensors, ensure that any extra cable lengths are properly shielded.</li> </ul>                                                                                                                                                       |
| Distance between sensor and display is over 100 metres.              | <ul style="list-style-type: none"> <li>• Insert Link 1 (see Figure 2 on page 4) to increase the current flow to the sensor, regardless of the input type used.</li> </ul>                                                                                                                                                                                                                                                                                                                                                                    |