

# MRPU5 - LCD RESETABLE COUNTER FLOWMETERS

(Screwed Insertion Paddlewheel)

## FEATURES

- 5 digit LCD resetable display Totaliser with pulse output option.
- Ideal in pipe diameters from 20 to 150 mm with simple installation pipe fitting/adapters.
- Suitable for measurement of liquids up to 50°C, with velocity range 0.6 to 8.0 metres/sec.
- $\pm 1\%$  accuracy 1- 7m/s,  $\pm 2.5\%$  accuracy 0.6-8m/s, with calibration certificate.
- Robust housing for harsh environments with durable alloy paddlewheel rotor.
- Sealed glass IP65 digital display compartment and lid protects LCD from sunlight. Easy access for re-calibration.
- Used in Irrigation, Transit mixers, Slumpstands and many other applications.



MRPU5, shown with GAL40M Pipe Adapter

The MRPU5 resetable counter flowmeter is designed and manufactured in Australia. The unit can be mounted to pipe sizes from 20 to 150 mm diameters. The MRPU5 1" BSP male threaded stem section allows the unit to be fitted to most 1" BSP female entries. Alternatively, MRPs are pre-fitted with the Manu pipe adapter fitting range, available in Class18 Cat19 PVC high pressure tees, Galvanized tees, cast Aluminium or Gunmetal 20mm flowtubes (for agitators), or saddle clamp agricultural poly-pipe fittings.

The MRPU5 is suitable for a wide range of medium to high flow range liquid flow measurement applications. Being internally battery powered, the unit is ideal in situations where no external power supply is accessible, making them totally portable resetable totaliser flowmeters.

The flowmeter's only moving part (an indestructible alloy rotor which turns as liquid flows past it) allows registration in Litres, KiloLitres or MegaLitres up to 1 decimal place on the 5 digit Liquid Crystal resetable display counter. The main body component, consisting of the electronic counter board, is housed in a robust Gunmetal housing. The LCD display is visible through the glass window and sealed by a metal locking ring. The MRPU5 is rugged for harsh environments. The impact resistant ABS lid protects the LCD and glass from prolonged sun exposure, contaminants and breakage.

To operate, lift the hinged lid. This action automatically turns on power, and the Liquid Crystal display is zeroed ready for measurement. Liquid flow causes counting on the display. Closing the lid resets the digits, and turns off battery power. The internal lithium battery has a life of 7-10 years. NOTE: A sleep mode function turns the display off after 30 minutes of no use. The display is re-awakened either by flow occurring or by closing and re-opening the lid.

## SPECIFICATIONS

<b>Flowrange</b>	0.6 - 8.0 m/sec velocity
<b>Accuracy</b>	2% (10:1 flow curve)
<b>Display readout</b>	<ul style="list-style-type: none"><li>• 5 digit LCD (12mm high) in Litres, KiloLitres or MegaLitres</li><li>• up to 1 decimal place</li></ul>
<b>Calibration</b>	via 3 internal pushbuttons
<b>Power Source</b>	3.7v Lithium battery (7-10 year life)
<b>Display Capsule Rating</b>	IP65
<b>Max. Operating Temperature</b>	50 °C
<b>Max. Pressure</b>	2000 Kpa, with Galvanised Iron and Gunmetal pipe fittings
<b>Pulse Output</b>	via optional plug set. Open Collector transistor, 5-25VDC

## INSTALLATION GUIDE

- To maintain the stated accuracy curve, a length of **straight pipe section** (of same diameter as adapter fitting) must be in place for a minimum 10x pipe diameters on the incoming side, and 5x diameters on the exit side, of the flowmeter.
- MRPU5 flowmeters are factory **calibrated to either vertical or horizontal pipe run positions (this must be specified when ordering)**.
- If mounting in pipe diameters contrary to factory set calibration, you may need to access the internal PCB pushbuttons to **change calibration settings**. See 'Re-Calibration'.
- A **range of pipe adapters** 20-150mm with 1" BSP (f) entries are available. Optionally, if mounting into your own fittings, make sure MRPU5 rotor is inline with flow direction. MRPU5s can also be mounted onto pipes with flow direction. MRPU5s can also be mounted onto pipes with tapping a 1" BSP(f) thread into the pipe, then simply screw the MRPU5 into position and calibrate accordingly. The MRPU5 paddlewheel must protrude at least one centimeter past the I.D. of the pipe. Usually MRPU5s are factory fitted to the chosen pipe adapter fitting.
- The flowmeter must measure in a **full pipe flow of liquid**.
- **Close lid after use**, to prevent LCD fading from prolonged exposure to direct sunlight.

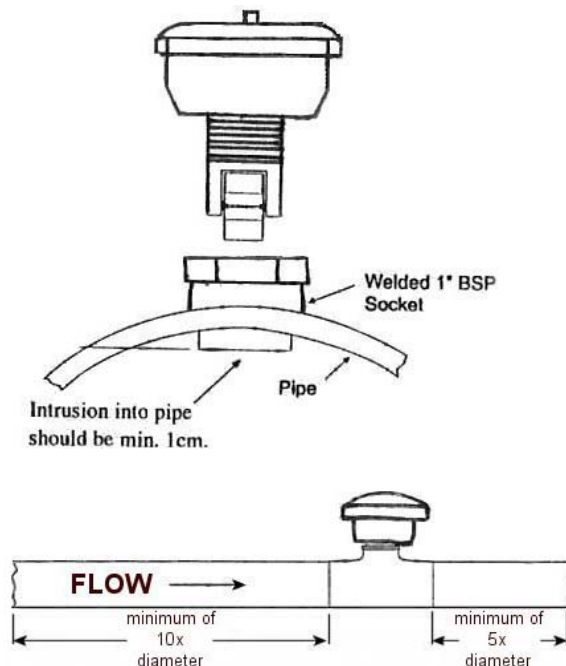

### PRODUCT ORDERING CODE FORMAT

(\*\* must specify Horizontal or Vertical pipe run)

**MRPU5- pipe adapter - No. of decimal places (0 or 1) - units\* - HV\*\* - options (if any)**

e.g. MRPU5-GAL50M-0-L-H = MRPU5, Gal. 50mm pipe adapter, no decimal place, Litres display, Horizontal run

#### MRPU5 PIPE ADAPTER FITTINGS

Order Code	size(mm)	Adapter Type
GAL25M	25	Galvanised Iron, threaded entries BSP(f). <b>NOTE: 25mm is supplied with pipe sections already fitted.</b>
GAL32M	32	
GAL40M	40	
GAL50M	50	
PVC25M	25	PVC Class 18, Cat 19 glue-in (f) socket connections for PVC pipe sections
PVC32M	32	
PVC40M	40	
PVC50M	50	
PVC80SCM	80	High pressure Saddle Clamp adapters for PVC pipe sections to 1400Kpa
PVC100SCM	100	
PVC150SCM	150	
SC50M	50	Poly-pipe agricultural Saddle Clamps.
SC63M	63	
SC75M	75	
SC90M	90	
SC110M	110	

\* units: L = Litres,  
KL = KiloLitres,  
M = Megalitres)

#### FUNCTION OPTIONS

-DR	disable reset
-P	IP67 pulse output plug-set (1 pulse per increment displayed)

#### SPARE PARTS

Code	Description
LM	Lid and magnet
PW	Paddlewheel (rotor) and bushes
PWAH	Axle, Tungsten Carbide
LB	3.7v Lithium battery
SCP	Plug 1" sealer

#### PIPE vs FLOW RANGE GUIDE for optimum performance

Pipe Size mm	Flowrange (Litres/sec)	
	Min.	Max.
20	0.25	2.5
25	0.3	3.0
32	0.5	5.0
40	0.8	8.0
50	1.2	12.0
65	2.0	21.0
80	3.0	32.5
100	5.0	50.0
150	11.5	123.0

#### MATERIAL SPECIFICATIONS

MRP housing and sealing ring	Cast gunmetal
Window	Tempered glass
Gasket	PVC
O-Ring	Neoprene
Rotor	Marine Alloy saf2205 and Delron bushes
Axle	Tungsten Carbide
Lid	ABS, ferrite magnet

## RE-CALIBRATION

- When ordering, **specify the intended pipe run: either horizontal, or vertical position.** The calibration (K-factor) characteristics can vary up to 6% from horizontal to vertical runs.
- **Recalibration of an MRPU5 is performed via three internal pushbuttons** (marked SET, LEFT and UP) mounted on the PCB. **To access the PCB**, open the hinged lid cover, and with a pair of multi-grips, grasp the metal locking ring and turn it anti-clock wise until the four lock tabs align with the four matching slots on the metal PCB housing. Remove the locking ring, and then remove the glass window.
- Now run liquid through the MRPU5 into a calibrated vessel or load cell, until 50 Litres is displayed on the MRPU5. For accuracy, keep flowrate continuous and above minimum flowrange for the pipe diameter.
- If the amount displayed matches the measured value within 2%, then no adjustment to calibration is necessary. Otherwise, the Calibration Value can be adjusted to fine tune the displayed Total:
  - to decrease the Total displayed on the LCD, increase the Calibration Value.
  - to increase the Total displayed on the LCD, decrease the Calibration Value.

Example:

If the Calibration Value is say '200', and the Total displayed is 3% higher than actual volume collected, then, to lower the displayed Total by 3% so as to match actual volume collected, the Calibration Value must be increased by 3% (i.e. increased by 3% x 200 = 6) to new value of '206'.

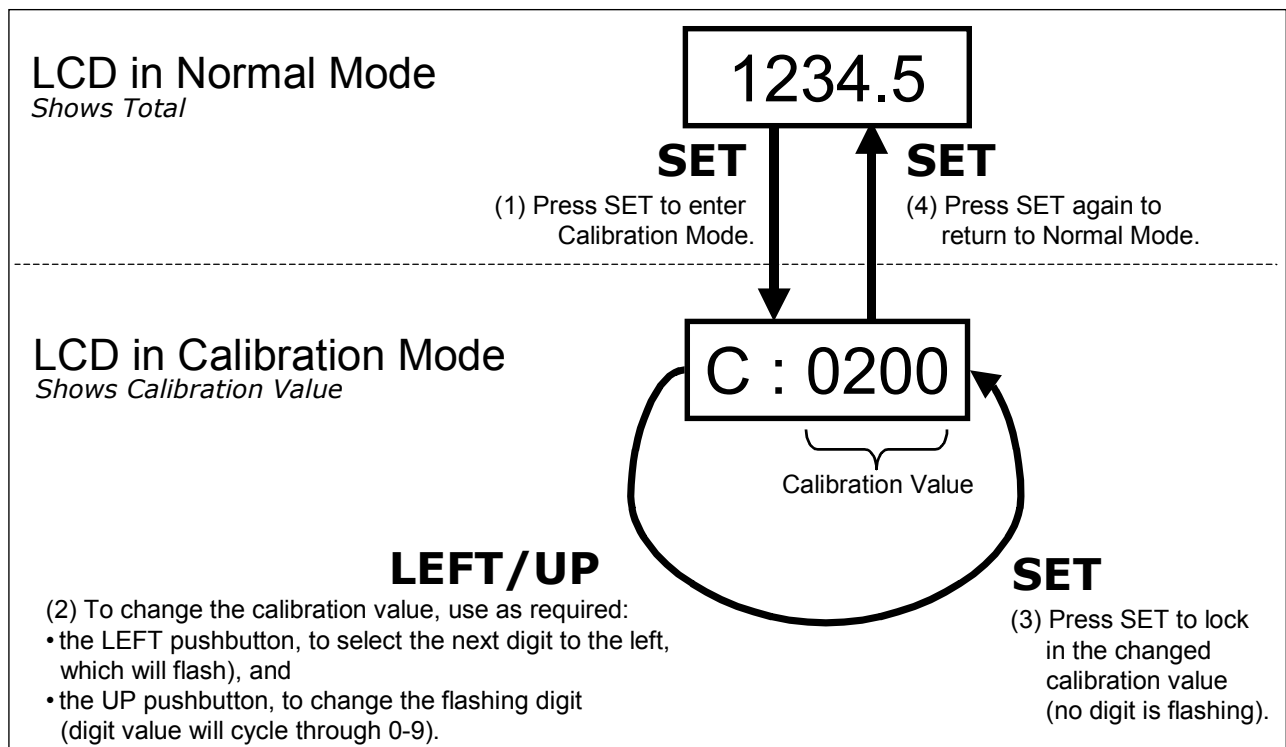

**Adjusting the Calibration Value using the internal Calibration pushbuttons SET, LEFT and UP.**

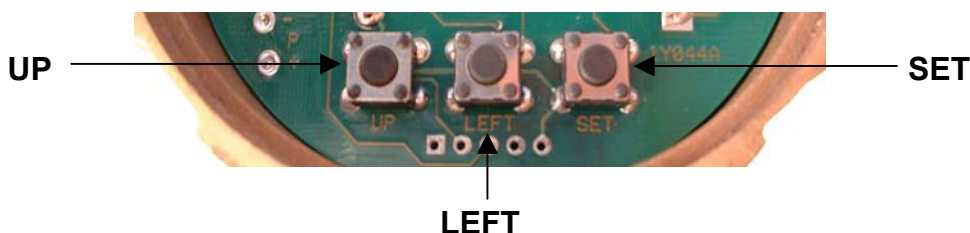

## MAINTENANCE

- If the LCD display is blank, the MRP5 may be in dormant mode because it is not receiving input pulses from its attached flowmeter. The LCD is reawakened once flow restarts, or by closing and re-opening the lid.
- If the flowmeter ceases to count, the paddlewheel may be blocked:
  - Grasp the readout head and turn it anti-clockwise, until it clears the threaded section.
  - Examine and, if required, clear debris from rotor.
  - If used with reclaimed water, then over time a calcium buildup may deposit on the rotor, so immerse the rotor in diluted acid to clear.
  - Re-insert the readout head and screw-in clockwise to its original position.
- If the MRP5 counts when there is no flow, a nearby 50Hz AC field is probably causing false counts. Move the flowmeter away from the 50Hz field, or move the source of the field if practical.
- To access the internal electronic display board to replace the Lithium battery:
  - refer to "Re-calibration" section for instructions to open the MRP5 to access the PCB.
  - Two screws secure the PCB - unscrew them and remove the PCB to access the battery on underside.
  - Replace battery with an equivalent unit.
  - Re-insert the PCB and glass.
  - secure the lock ring, and seal under lock ring with silicon, as a precaution against liquid ingress.
- When not in use, keep the lid closed. If prolonged direct exposure to sunlight causes the LCD to become faint or discoloured, return the MRP5 to Manu Electronics for servicing.



Internal view - PCB and 3 calibration pushbuttons

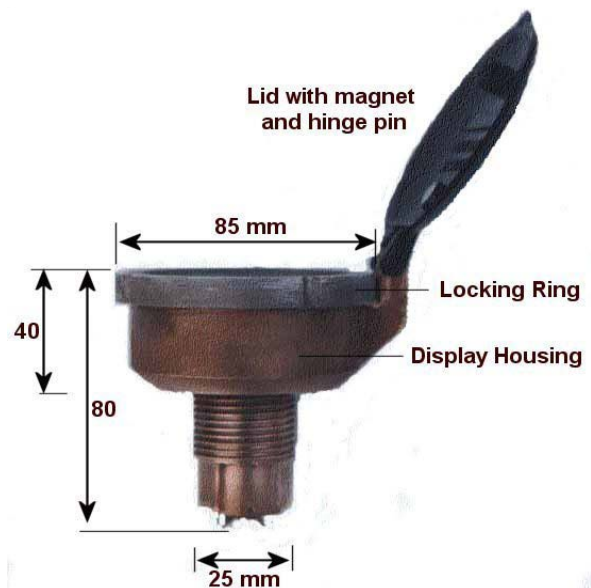

Side view, with dimensions

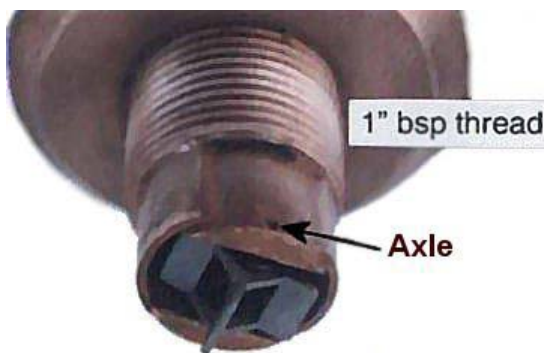

Paddlewheel

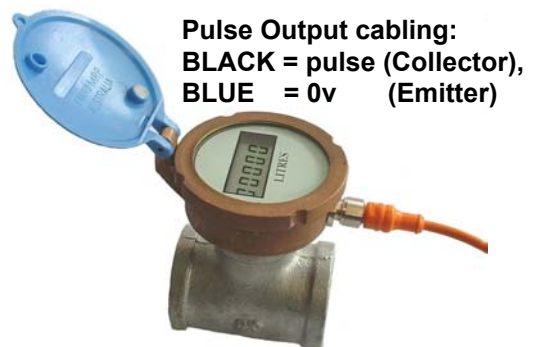

With optional IP67 Pulse Output plug set.

**ManuFlo**®™

Flow Measurement Products

ABN: 47-002-946-303

Email: [sales@manuelectronics.com.au](mailto:sales@manuelectronics.com.au)

Web: [www.manuelectronics.com.au](http://www.manuelectronics.com.au)

Rev. 0406/1

a division of

**MANU ELECTRONICS PTY LTD**

41 Carter Road Brookvale

Sydney NSW 2100 Australia

Ph: + 61 2 9938-1425, 9905-4324

Fax: + 61 2 9938-5852